

LINEAR **M**EASUREMENT **I**NSTRUMENTS, Corp.

Research, Development and Manufacturing of Precision Measuring Systems

**SUPPLEMENT TO STANDARD CALIBRATION INSTRUCTION
FOR THE LMI 200-S / 200-SB**

After completion of the calibration steps for the LMI 200 to the LMI 585 or 440 do the following steps:

1. Insert the LMI 200 into the 302-ADJ kick-up adapter & tighten screw. (see figure1)
2. Put the 302-ADJ into the mastering position on the master block. (see figure1)
3. Repeat only the mastering step from the appropriate instructions. The gage should now be zeroed and ready for use.

Note: Since this adapter is adjustable make sure that you “re-master zero” on the LMI 200 after making a position adjustment.

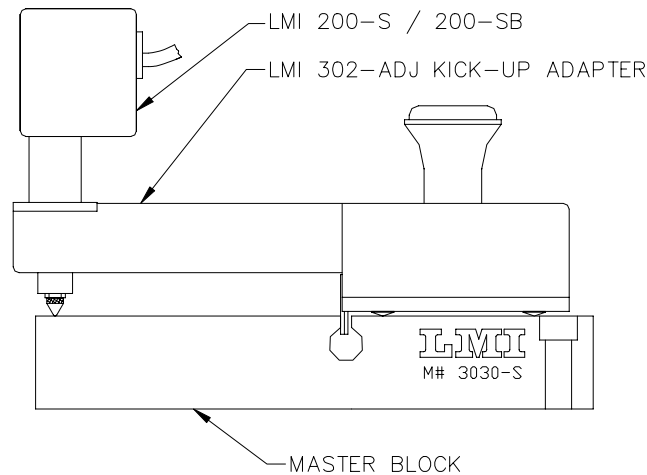

Figure 1