

This drawing contains designs and other information which are the property of LMI Corporation. This drawing may not, in whole or in part be duplicated or disclosed or used for manufacture of the part disclosed herein, without the prior written permission of LMI Corporation. LMI is dedicated to continuous product development and therefore reserves the right to modify the design without notice. Contact LMI to verify current design specifications.

Tracing Template

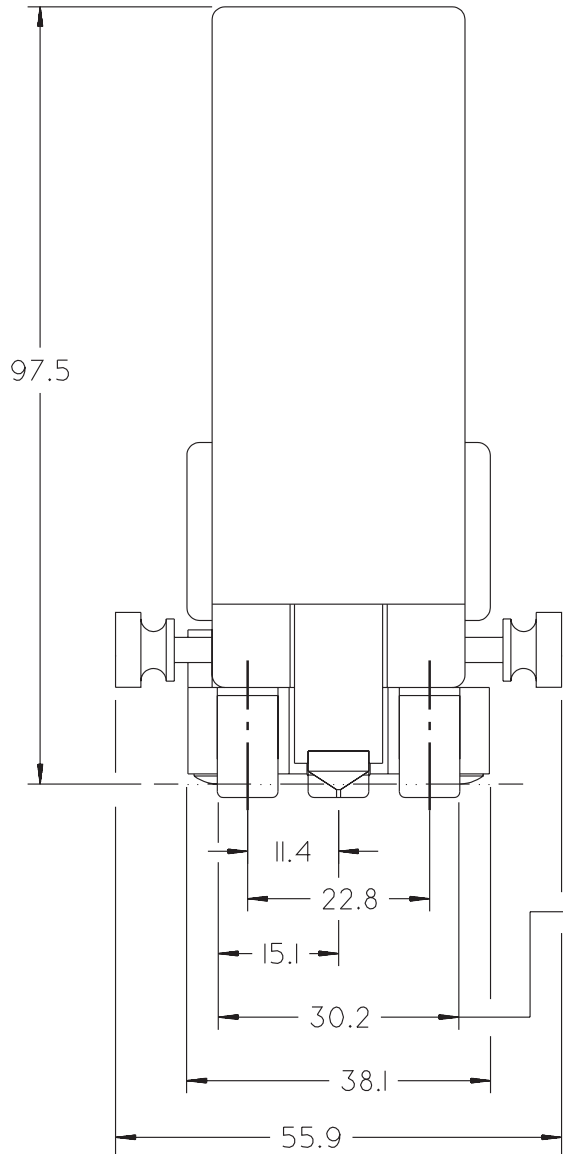

CONTACT FEET
CENTER TO CENTER

± 2.0 FLUSH TIP ADJUSTMENT

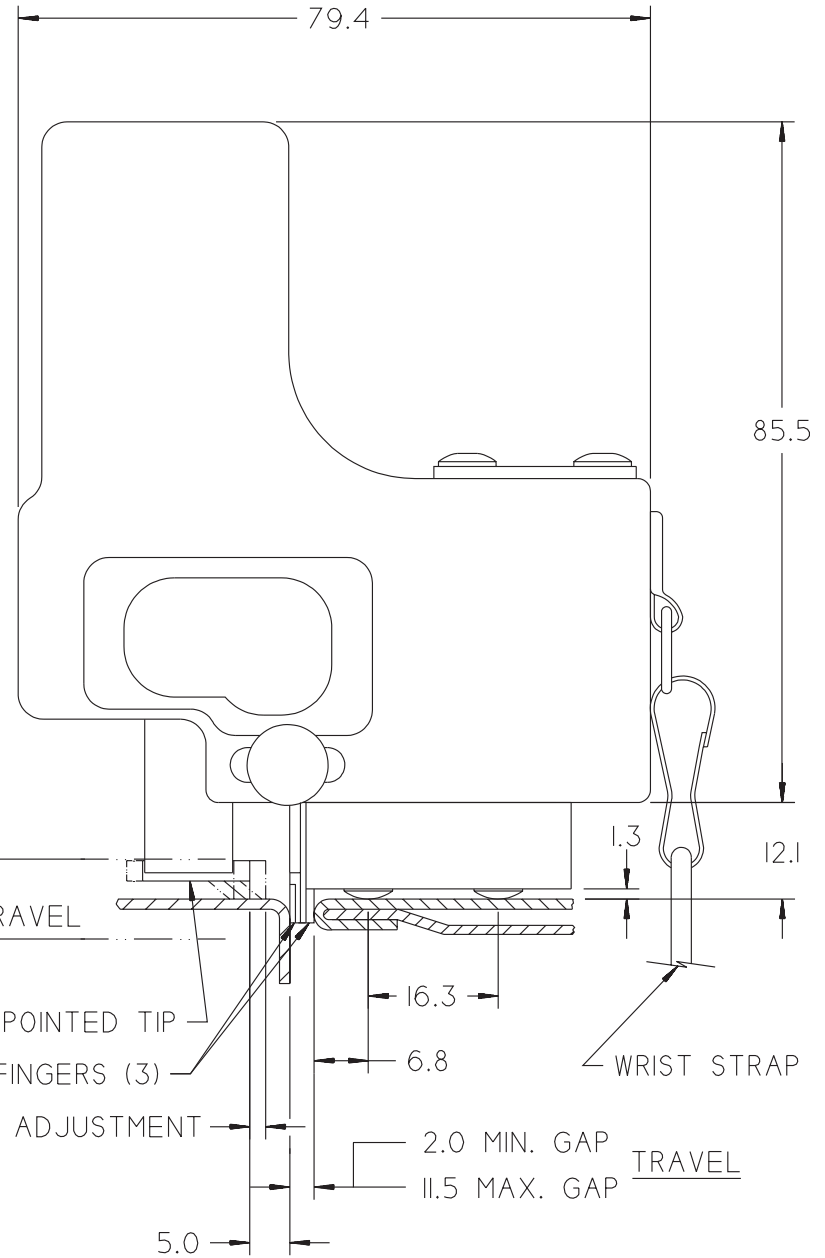

OPTIONAL AVAILABLE GAP FINGER LENGTHS:
0-2, 2-4, 4-6, 6-8, 8-10 MILLIMETERS BELOW FLUSH

LMI
Corporation
Phone # (810) 714-5811

TITLE: LMI 24I-BWV2 MAGNETIC FLUSH & GAP GAGE W/
NON-MARRING FEET & FINGERS (PATENT PENDING)

SHEET: 1 of 1

REV DATE: 11/05/99