

This drawing contains designs and other information which are property of LMI Corp. This drawing may not, in whole or in part, be duplicated or disclosed or used for manufacture of the part disclosed herein, without the prior written permission of LMI Corp. LMI is dedicated to continuous product development and therefore reserves the right to modify the design without notice

TRACING TEMPLATE

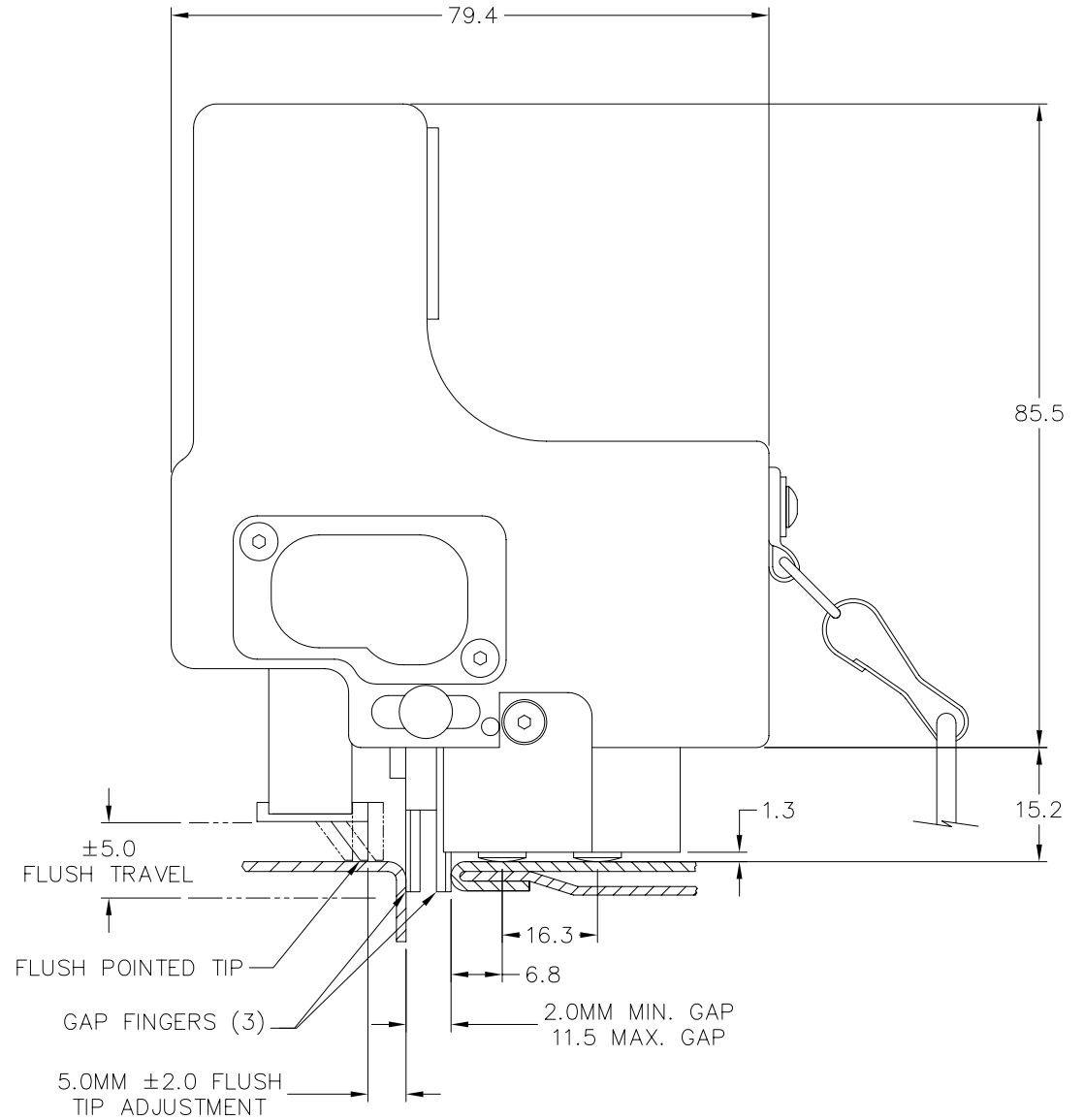
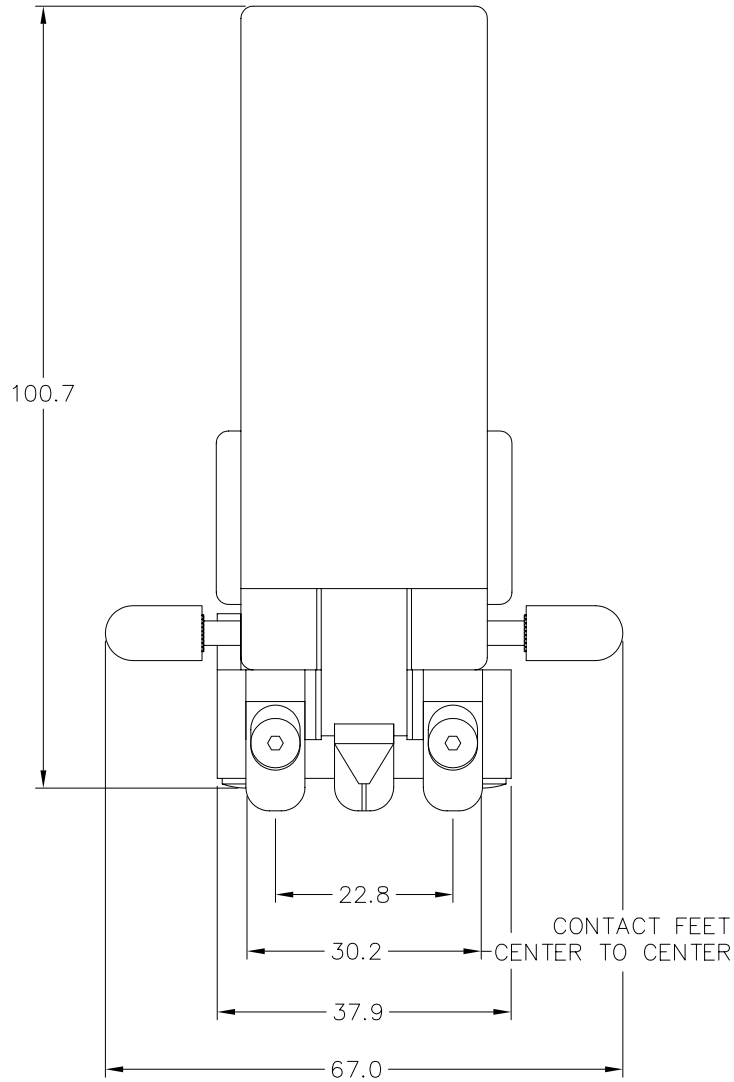

OPTIONAL AVAILABLE GAP FINGER LENGTHS:
0-2, 2-4, 4-6, 6-8, 8-10 MM BELOW FLUSH

LMI
PHONE #(810) 714-5811

TITLE: 241-FG FLUSH & GAP GAGE	
NON-MARRING CASE CONSTRUCTION	
SHEET: 1 OF 1	REV DATE: 11/19/04