

101 N. Alloy Dr.
Fenton, MI 48430



Ph (810) 714-5811
Fax (810) 714-5711

CustomerService@lmicorporation.com

LINEAR **M**EASUREMENT **I**NSTRUMENTS, Corp.

Research, Development and Manufacturing of Precision Measuring Systems

LMI 595



USER GUIDE

LMI 595 DIGITAL TRANSMITTER

LMI Corporation

Section		Page
1	PRELIMINARY INFORMATION	
1.1	Warranty	3
1.2	LMI Customer Service	3
1.3	Returns for Service	3
1.4	LMI Technical Support	4
2	LMI 595 Plus OVERVIEW	
2.1	595 Plus Front View	5
2.2	595 Plus Back View (Battery Compartment)	6
2.3	595 Top View (Gage Ports)	7
2.4	Keypad Functions	10
2.5	Powering On for the First Time	11
2.6	LCD Description	11
3	MENU STRUCTURE	
3.1	Main Menu	12
4	CALIBRATE MENU	
4.1	Port 1a Calibrating a 200 Series Probe	14
4.2	Port 1b Calibrating a 300 & 770 Flush and Gap Gage	17
4.3	Port 2 Calibrating a 241 Series Flush and Gap Gage	20
4.4	Port 3 Calibrating a Caliper	24
4.5	Calibration Errors	25
4.6	Reviewing Previous Calibrations	25
5	COMMUNICATIONS MENU	
5.1	Format (Export Formats)	26
5.2	Baud Rate	28
5.3	TX Date/Time (Sending Date/Time Stamps)	28
5.4	TX Labels (Sending Labels)	29
5.5	Serial [On]/Off	29
5.6	Power Saver option for communications only (For "RF" option ONLY)	29
6	ADVANCED SETUP MENU	
6.1	Advanced Setup	30
6.2	Configure Ports	31
6.2.1	Caliper, TruPosition Probe	33
6.2.2	Labels	34
6.2.3	CALSPAN	35
6.2.4	Offsets	36
6.2.5	Auto Read, Dwell Range and Time	38
6.2.6	Auto Select for a 300/770	38
6.3	Port Polarity	38
6.4	Ports Display	39
6.4.1	View Places	39
6.4.2	Send Places	39
6.4.3	Round To	40
6.5	F/G Toggle	40
6.6	Null Meter	41
7	PREFERENCES MENU	
7.1	Units	42
7.2	Audio	42
7.3	Date/Time Display on Screen	43
7.4	Set Date/Time	43
7.5	Power Save	45
8	SYSTEM SETUP MENU	
8.1	Security	46
8.2	Set EE Defaults	46
9	REVIEW READINGS MENU	
9.1	Review Latest Readings	47
9.2	Saving Readings and Reviewing Saved Readings	48
9.3	Sending Saved and Latest Readings	48
9.4	Setting up your PC to receive data from the 595	48
10	HELP MENU	
10.1	Code Version and LMI Information	49

LMI Corporation

SECTION 1: PRELIMINARY INFORMATION

1.1 Warranty Information

In the USA, this unit is warranted by LMI against defects in materials and workmanship for 1 year from date of original purchase. If you transfer ownership, the warranty is automatically transferred to the new owner and remains in effect for the original 1 year period. During the warranty period we will repair or, at our option, replace at no charge product that proves to be defective, provided it is returned, shipping prepaid to LMI.

This warranty does not apply if the product has been damaged by accident or misuse or as a result of service or modification by other than LMI, or by hardware, software, interfacing or peripherals not provided by LMI.

This is your warranty.

Please retain this document for your records.

No other express warranty is given. The repair or replacement of a product is your exclusive remedy. Any implied warranty of merchantability or fitness is limited to the 1 year duration of this written warranty. Some States do not allow the exclusion or limitations of incidental or consequential damages, so the above exclusion or limitations may not apply to you.

1.2 LMI Customer Service

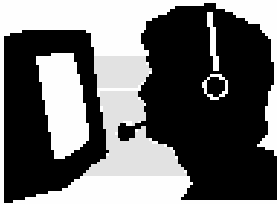

LMI Customer Service can be reached at **(810) 714-5811** Monday through Friday between 8:00 a.m. and 5:00 p.m. Eastern Standard Time.

Call LMI Customer Service to:

- Place orders
- Return LMI equipment for service
- Inquire about the status of an order or repair

1.3 Returns for Service

- Contact Customer Service for a Return Material Authorization (RMA) number. Include a detailed description of the problem.
- Pack the equipment properly. Use the original shipping container, if possible. LMI cannot assume responsibility for damage caused by improper packaging.
- Send the equipment to the following address:

LMI Corporation 101 N. Alloy Drive Fenton, MI 48430

LMI Corporation

1.4 LMI Technical Support

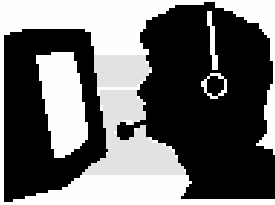

LMI Technical Support experts are only a phone call away. Contact Technical Support for the following reasons:

- To assist in setup and configuring LMI equipment
- To help implement data collection applications
- To troubleshoot LMI equipment

There are several ways to contact LMI Technical Support:

- **By Phone:** Call **810-714-5811** Monday through Friday between 8:00 a.m. and 5:00 p.m. (Eastern Standard Time) for answers to your questions.
- **By Fax:** Dial **810-714-5711** anytime to fax your questions to LMI Technical Support. Please include in the transmission your name, phone number, hours you can be reached, and a *detailed description* of the problem.
- **By Email:** techsupport@lmicorporation.com You can email your questions anytime. Please include your name, phone number, and a *detailed description* of the problem.

LMI On-Site Training

LMI Technical Support provides on-site training for all LMI products. Contact LMI Support Services at 810-714-5811 for pricing and scheduling information. Schedule a day at your facility or at LMI in Fenton, Michigan.

LMI Website

Please visit us on the web @ www.lmicorporation.com for more information.

LMI Corporation

SECTION 2: LMI 595 OVERVIEW

2.1 Front View

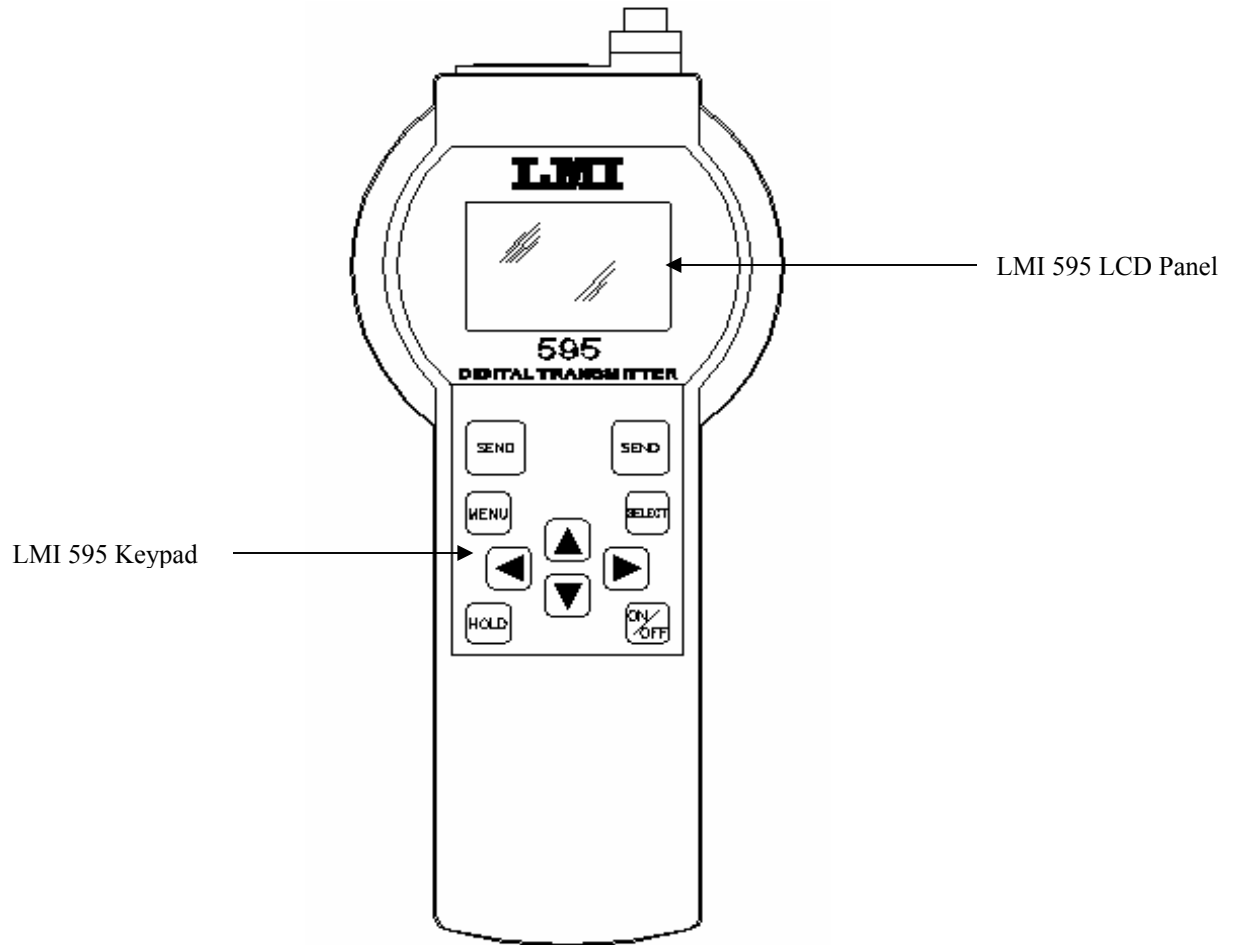

- **LCD Panel:** The user interface for viewing gage readings and displaying all the menus and options.
- **Keypad:** 10 keys used to navigate through the menus.

LMI Corporation

2.2 Back View (Battery Compartment Access)

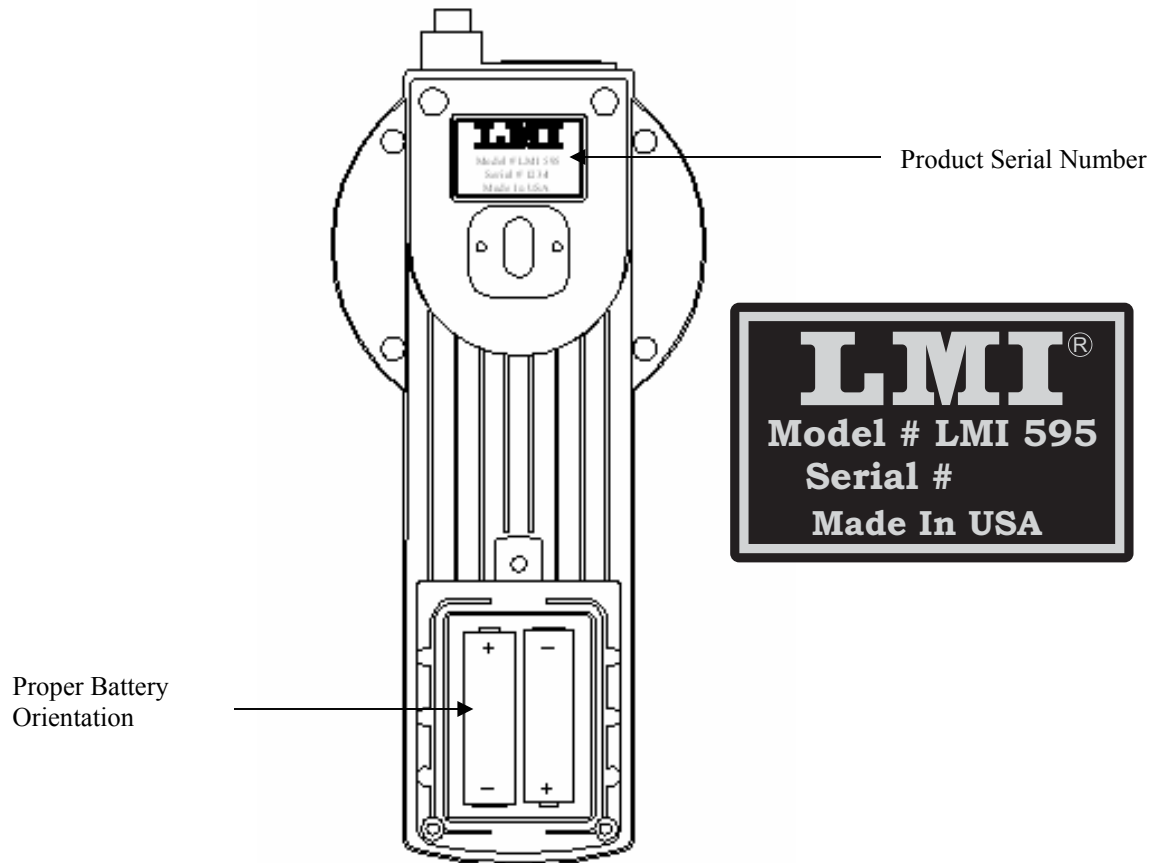

- **Product Serial Number:** Reference the serial number for warranty information.
- **Battery Compartment Access:** View shows battery cover removed. To remove the batteries detach the belt clip and remove the protective front keypad cover. Pull back the rubber boot and pull up with your thumb on the battery cover. The 595 accommodates two AA size batteries. The alkaline batteries supplied with the unit will provide over 200 hours of average use. Hours will vary depending on the options selected and the amount of data transmitted.
 - When the batteries are removed gage calibrations are retained and will not be lost. If the batteries are removed for more than 4 minutes the date and time will need to be reset upon powering up.
 - Do **NOT** put batteries in backwards or mix battery types.

LMI Corporation

2.3 Top View (Gage Ports)

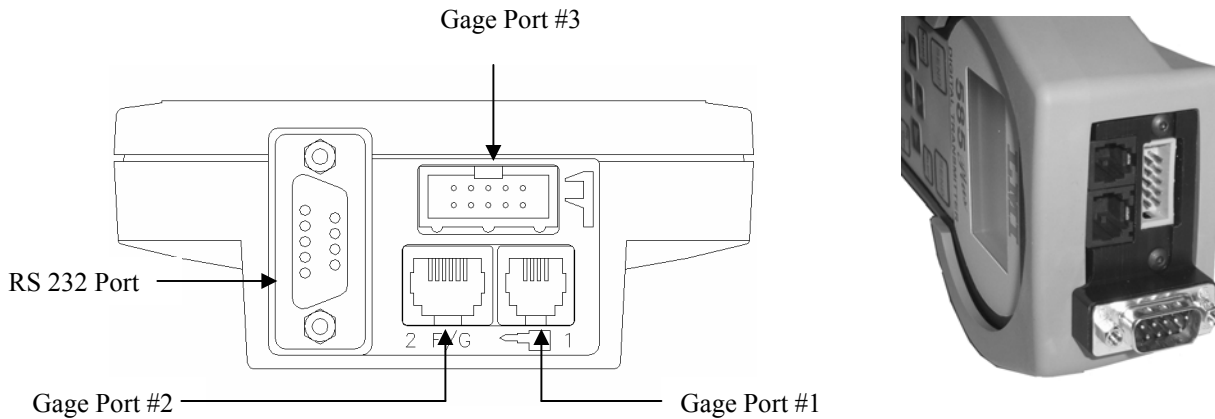

- **Gage Port #1:** 4-pin connector used to connect LMI gages with a single analog output. Gages include the 200 Series probes, 2079 & 2080 gap gages, 237 & 238 seal gap gages with 4-pin jack, and the 300 & 770 flush and gap gages. Gages are connected to the port with a standard LMI 6009 cable. Within the 595 the gages for Port #1 are separated into two screens port 1a and 1b. Port 1a is for connecting gages like the 200 Probe series with one master point. The default gage label for this screen is 1PROBE. Port 1b is used for the 300 and 770 flush and gap gages which have two master points, one for flush and one for gap. The default screen label is 1FLUSH and the <SELECT> key is used to toggle to 1GAP. To view the different gage screens use the ► or ◀ to toggle to the different screens.

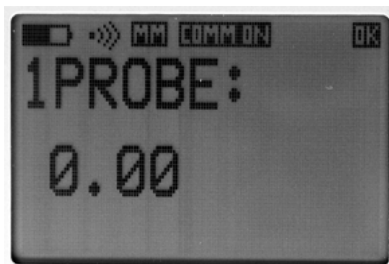

Port 1a (200 Probe Screen)



Port 1b (300 or 770 Screen)

LMI Corporation

- **Gage Port #2:** 6-pin connector used to connect LMI gages with two analog outputs. Gages include the 241 Series flush and gap gages, and an Analog TruPosition gage which has two live readings on the screen. Gages are connected to the port using a standard LMI 6025 cable.

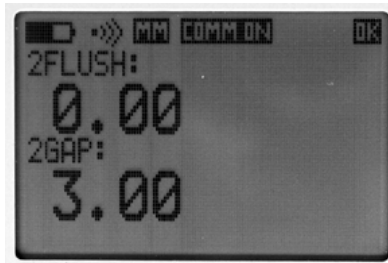

Port 2a & Port 2b (241 Gage Screen or Analog TruPosition Screen)

- **Gage Port #3:** Connect the 10-pin interface cable to the LMI 595. This setting reads Mitutoyo output and can accommodate most Calipers. To setup the Caliper display screen, toggle the ► or ◀ to the screen setting 3CALIPER. Gage Port #3 can also display Digital TruPosition readings and calculations

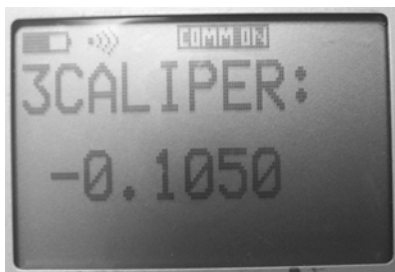

Port 3 (CALIPER Screen)

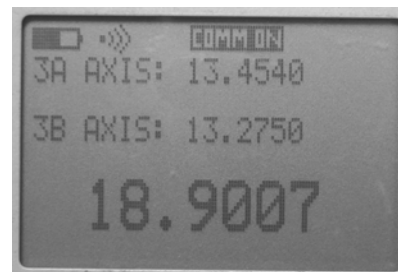

Port 3 (TruPosition Probe Screen)

If the Caliper is not connected correctly to the LMI 595 or powered on a display image will be seen. Please re-connect the caliper.

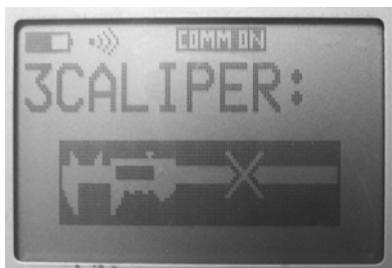

Caliper not connected



TruPosition Probe not connected

LMI Corporation

If the TruPosition Probe is not connected correctly to the LMI 595 or powered on a display image will be seen. Please Turn on the TruPosition Probe.

- **RS-232 Port:** This is the communications port used to send readings from the 595 to a PC using an LMI 6020 cable connected at the top of the device.
- **Mitutoyo Port:** This communication port will interface with Mitutoyo Digital Outputs.

NOTES:

The Caliper units mode can be changed from metric (mm) or imperial (inches), by changing the mode on the Caliper itself.

LMI Corporation

2.4 Keypad Functions

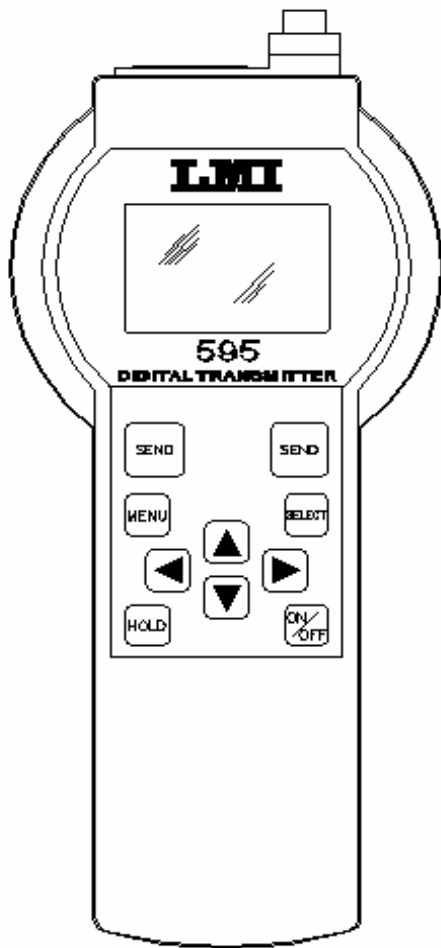

- **ON/OFF:** Powers unit on or off
- **HOLD:** Press button to freeze or unfreeze the current gage reading(s) displayed.
 - ✓ Note: Shortcut key for quick zeroing. Hold the key down for 2 seconds in order to re-zero the current gage port displayed.
- **ARROW KEYS:** Up and down arrows are used to scroll and highlight items within a menu or increase/decrease values for settings. The right and left arrows are used to move left or right on highlighted values. The right arrow is used to access sub-menus while the left arrow is used to return to a previous menu.
 - ✓ Note: Left and Right arrows will also scroll through the gage ports when not in the menu structure.
- **SELECT:** Selects the highlighted menu option or will toggle between master points of the active gage port.
- **MENU:** Press button to access main menu
- **SEND:** Data transmission of current gage reading(s) displayed. The Send key is also a shortcut to exit the menu structure back to the gage readings. Both SEND buttons function identically.

NOTE: Do not use sharp objects (pen, pencil, etc) to push the buttons on the keypad of the 595. This will damage the unit and void the warranty

LMI Corporation

2.5 Powering on for the First Time

When you power on for the first time you will be prompted to enter the current date and time. Use the ▲ and ▼ arrows to change the highlighted item to the current month/day/year and time. The ► and ◀ arrows are used to highlight the next item such as month, day etc. Press the <SELECT> key when finished. The date and time is used to date stamp your last gage calibration and also used to date stamp your data that is sent to a PC.

2.6 LCD Description

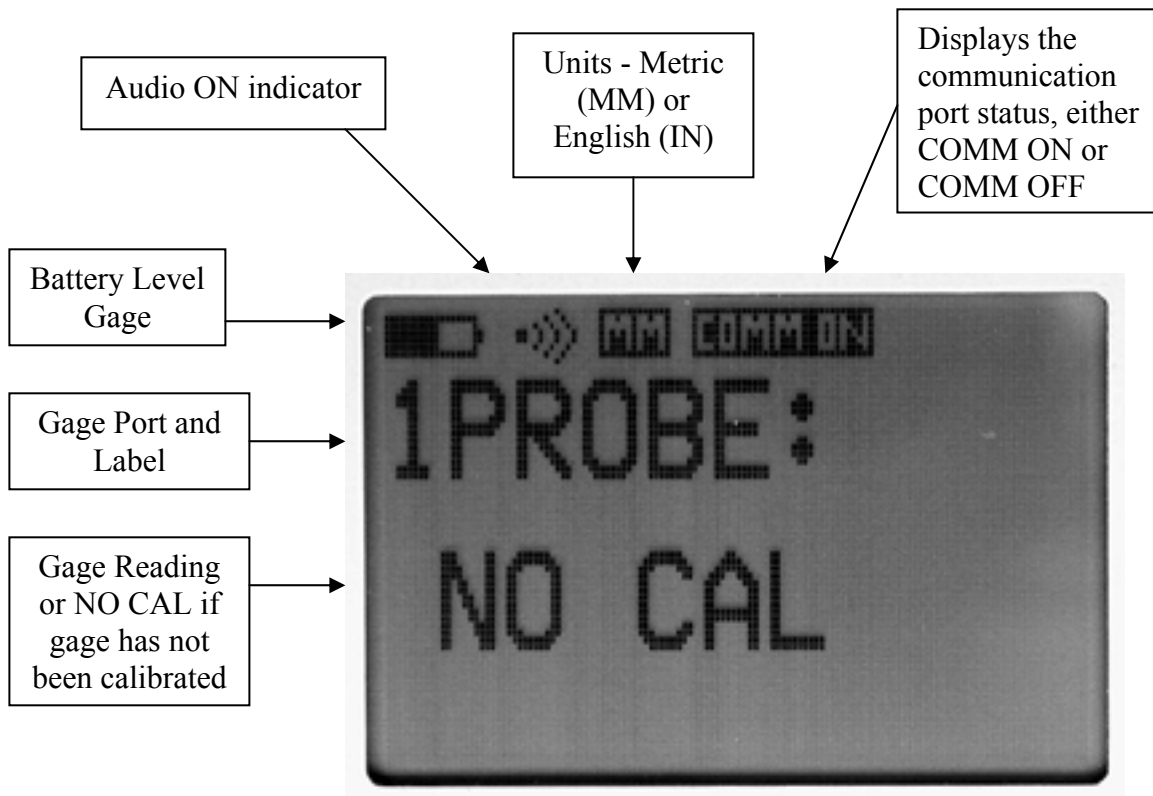

- The battery level indicator is the fuel gage for your battery. There are six battery monitor levels shown before the battery icon is empty. When the battery level is nearly depleted, a warning message “LOW BATTERY” will appear on the screen to indicate you need to replace the batteries. Hit any key to continue normal operation and the battery icon will display “LOW” inside the icon. The unit will operate at full accuracy under low battery conditions but will shutdown if the battery reaches a critical low level. This insures no corrupt data will be displayed or transmitted.
- To prevent the chance of the unit shutting down, it would be best to change the batteries as soon as possible.

LMI Corporation

SECTION 3: MENU STRUCTURE

3.1 Main Menu

When the unit is powered up, the LMI logo screen will appear for 3 seconds. To bypass this screen hit any key. After the date and time have been set the unit will power on to the last gage port you were currently viewing.

The following are basic instructions for navigating the menu structure:

- To enter the main menu, simply press the <MENU> key or the ▼ (see display below)
- To escape the menu structure at any time simply press <SEND>
- To access a sub-menu press <SELECT> or ►
- To go back to the previous menu, press ◀
- To make a final selection press <SELECT>

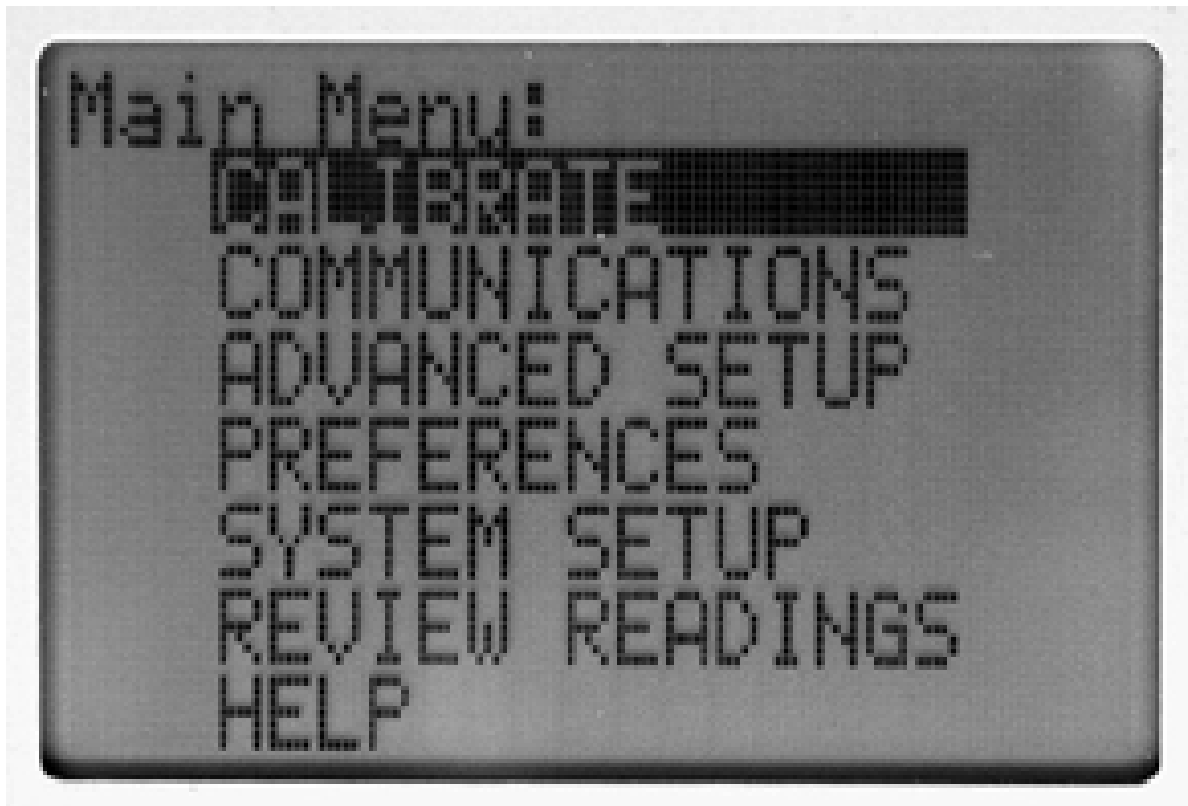

LMI Corporation

The following table lists the main menu items and their corresponding sub-menu. Each menu item will be explained in detail in the following sections.

MAIN MENU		1 st SUB-MENU
CALIBRATE	▶	PORT 1a (200 Series)
		PORT 1b (300,770)
		Port 2a (241 Flush)
		Port 2b (241 Gap)
COMMUNICATIONS	▶	FORMAT [Export1]
		BAUD RATE [9600]
		TX DATE/TIME [Never]
		TX LABELS On/[Off]
		SERIAL [On]/Off
		POWER SAVE (COMMUNICATIONS ONLY/FOR RF UNITS)
ADVANCED SETUP	▶	CONFIG PORTS
		PORT POLARITY
		PORT DISPLAY
		F/G TGL [MANUAL]
		NULL METER
PREFERENCES	▶	UNITS [mm]
		AUDIO [On]/Off
		DATE/TIME On/[Off]
		SET DATE/TIME
		POWER SAVE [20]
SYSTEM SETUP	▶	SECURITY On/[Off]
		SET EE DEFAULTS
REVIEW READINGS	▶	RVW LATEST READINGS
		RVW SAVED READINGS
		SAVE LATEST READINGS
		SEND LATEST READINGS
		SEND SAVED READINGS
HELP	▶	Code Version and LMI information

LMI Corporation

SECTION 4: CALIBRATE MENU

4.1 Port 1a Calibrating a 200 Series Probe

Prior to starting calibration, make sure your 200 Probe is connected to the Gage Port #1 (Ref. 2.3) on the 595 using a 6009 cable. A 210 Master Block is required to properly calibrate a 200-S or –SB Probe. The steps below will guide you through the calibration procedure with pictures of the 595 LCD screen and drawings of the 200 Probe to help.

NOTE: Under the ADVANCED SETUP/CONFIG PORTS menu, the CALSPAN of Port 1a should be set to 10.00mm

- Press <MENU> to enter the main menu
- “Calibrate” should already be highlighted like the figure below. Press <SELECT> or ►

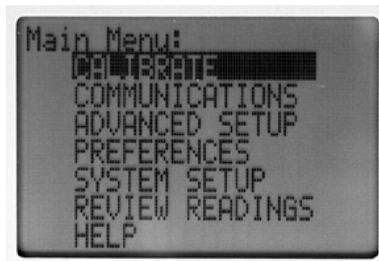

- Highlight Port 1a then press <SELECT>
-

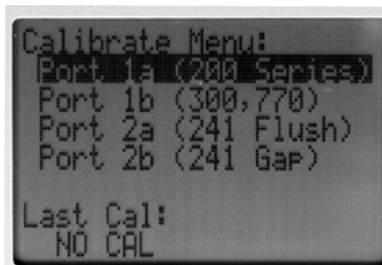

- CAL LOW will be displayed on the screen. Insert the 200 probe in the “LO” step of the 210 Master block and press <SELECT>

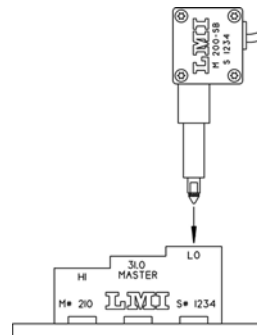
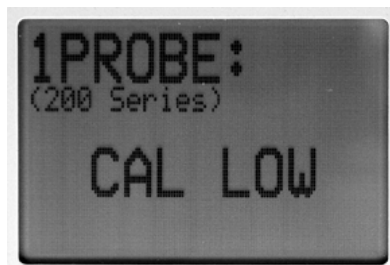

LMI Corporation

- The screen will then toggle to CAL HIGH. Insert the 200 probe in the “HI” step of the 210 Master block and press <SELECT>

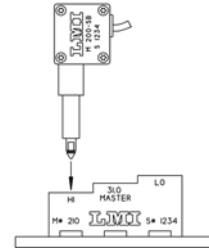
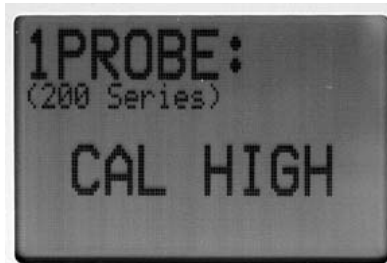

- The screen will then toggle to CAL MASTER. Insert the 200 probe in the “31.0 Master” step of the 210 Master block and press <SELECT>

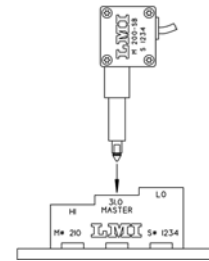
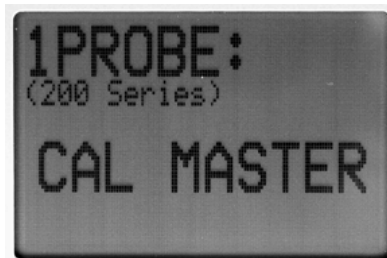

- Calibration is complete and the screen takes you back to the “Calibrate Menu:” screen. To exit and view your readings, press <SEND>.

- You should be able to view your readings on the screen labeled 1PROBE. Use the ► or ◀ to toggle between three gage screens if 1PROBE is not shown. The screen below shows 1PROBE with a gage reading of 0.70mm. Insert the gage back into the “31.0 Master” step to verify zero or master. This calibration procedure will produce a negative reading when the Probe is extended beyond the 31.0 Master Point.

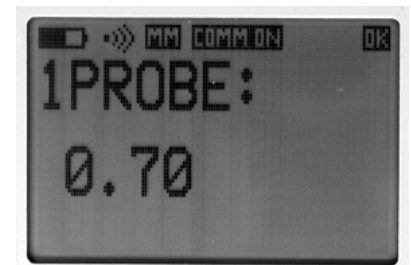

- To reverse the signs, go to the main menu. Go to Advanced setups and hit <SELECT>. Go to Ports Polarity. Press <SELECT>. Choose the port you are using and press <SELECT>...the port readings will change to “Inverted”

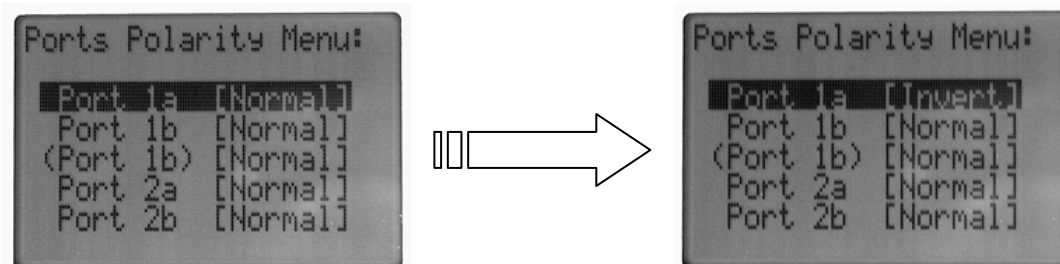

NOTES:

- 1) If you are using the 200-SB with the 235/236 seal gap blocks, you will want to CAL MASTER on the LO step of the Master Block and put in the proper offset in the ADVANCED SETUP>PORT CONFIG>Port 1a menu. The offset should be set to the 235/236 minimum gap check (10.0mm).

LMI Corporation

2) A 200-SF Probe has 22.0mm of travel so the CALSPAN needs to be changed from the default 10.00 to 22.00mm. Go to the ADVANCED SETUP>PORT CONFIG>Port1a menu to adjust the CALSPAN to 22.00mm. The 210 Master Block will also be replaced with the 214 Master Block with a 54.0mm Master.

LMI Corporation

4.2 Port 1b Calibrating a 300 or 770 Flush and Gap Gage

Prior to starting calibration, make sure your 300 or 770 is connected to Gage Port #1 (Ref. 2.3) on the 595 using a 6009 cable. A Master Block is required to properly calibrate your gage. The 300 uses a 3030 master block and the 770 uses a 720 master block. The steps below will guide you through the calibration procedure with pictures of the 595 LCD screen and drawings of the gage to help.

NOTE: Under the ADVANCED SETUP>PORT CONFIG menu the CALSPAN of Port 1b should be set to 10.00mm

- Press <MENU> to enter the main menu
- “Calibrate” should already be highlighted like the figure below. Press <SELECT> or ►

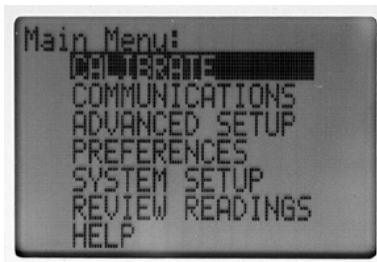

- Highlight Port 1b and press <SELECT>

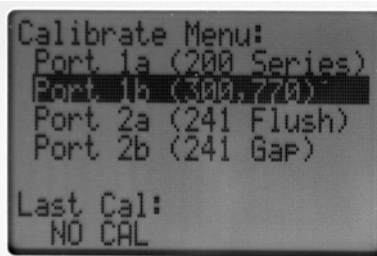

- CAL LOW will be displayed on the screen. Fully retract the gage and press <SELECT>

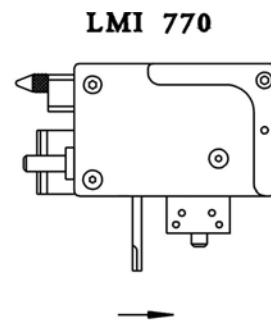
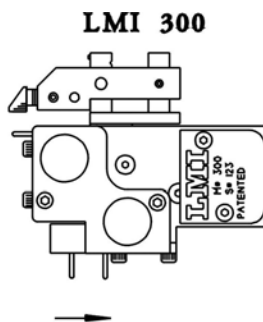
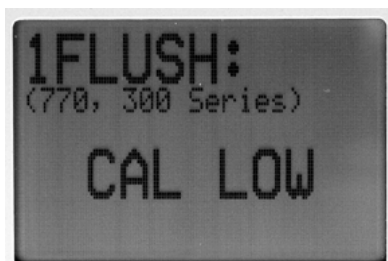

LMI Corporation

- The screen will then toggle to CAL HIGH. Release the gage to its fully extended position and press <SELECT>

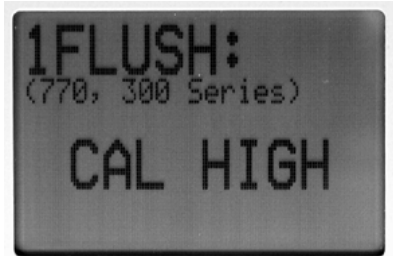
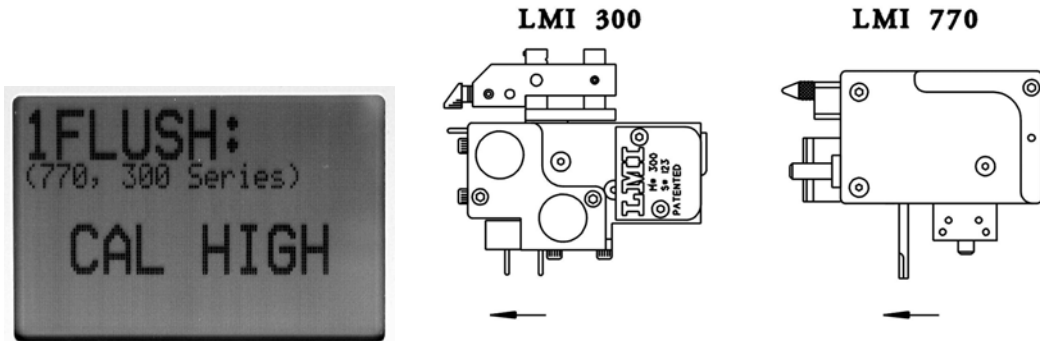

- The screen will then toggle to CAL MASTER. Place the gage in the “Flush Master Position” and press <SELECT>

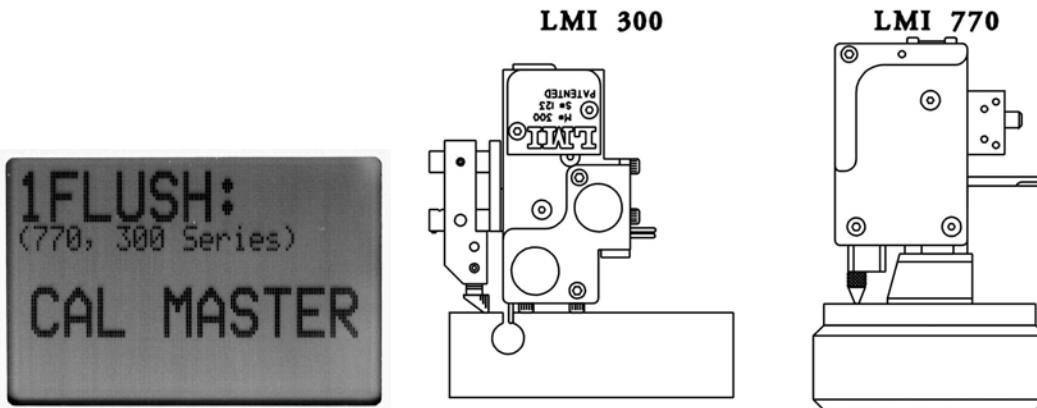

- The screen will then toggle again to CAL MASTER for its 2nd master position. Rotate the gage and place it in the “Gap Master Position” and press <SELECT>

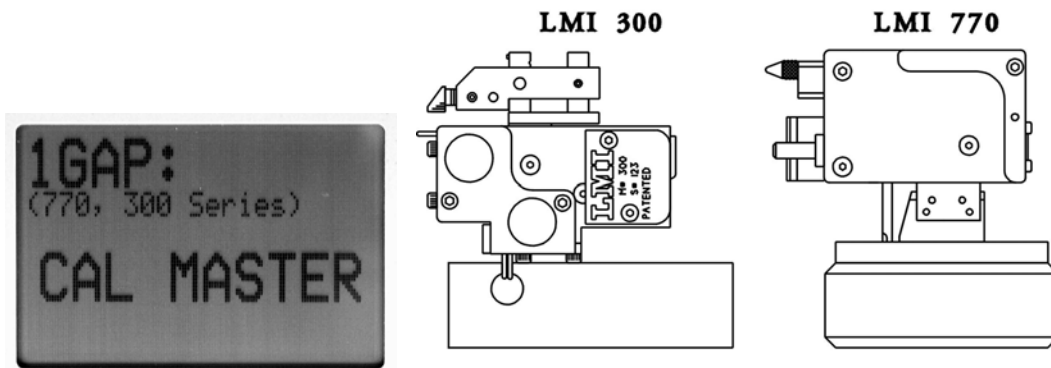

LMI Corporation

- You are then prompted to enter in an offset for the “Gap Master Position”. Use the arrow keys to adjust the value of the offset. If you are reading deviation then you can leave the offset value at 0.00mm. If you want to read actual gap, adjust the offset to 3.00mm. Once you have adjusted to the readings you want, press <SELECT>

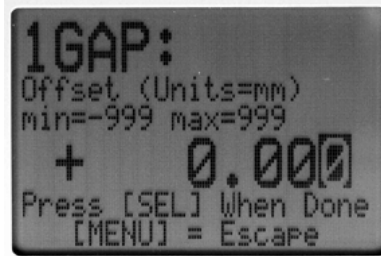

- Calibration is now complete and the screen takes you back to the “Calibrate Menu” screen. To exit and view your readings, press <SEND>.
- You should be able to view your readings on the screen labeled 1FLUSH. Use the left ◀ or right ▶ arrow to toggle between the three gage screens if 1FLUSH is not shown (if “AUTOSEL” is on, you will only have two screens). The screen below shows 1FLUSH with a gage reading of 0.0mm. The second screen shows 1GAP with a reading of 3.00mm. To toggle between the flush and gap master points, press <SELECT>. Insert the gage back into the Master Block to verify zero or master points.

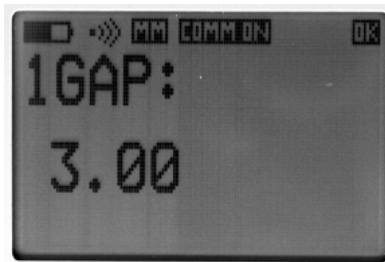

NOTES:

This calibration procedure will produce a positive reading when the gage is extended beyond the master point.

- To reverse the signs, go to the main menu. Go to Advanced setups and hit <SELECT>. Go to Ports Polarity, hit <SELECT>. Choose the port you are using and hit <SELECT>...the unit will change to “Inverted” (ref 6.3)

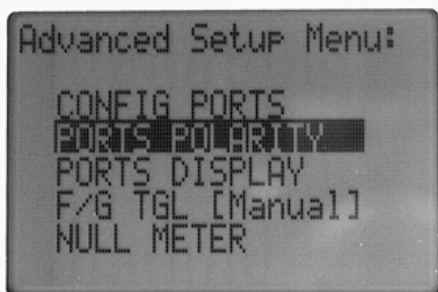

Port 1b = FLUSH
(Port 1b) = GAP

You can invert either line, or both, depending on you application.

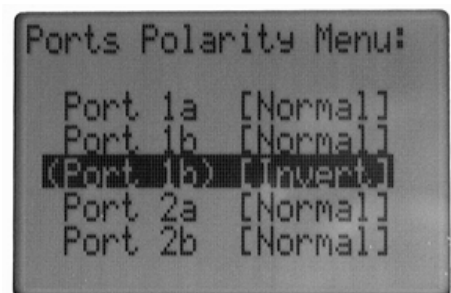

LMI Corporation

4.3 Port 2 Calibrating a 241 Series Flush and Gap Gage or Analog TruPosition Probe

Prior to starting calibration make sure your 241 or 241-BWV2 is connected to the Gage Port #2 (Ref. 2.3) on the 595 using a 6025 cable. A Master Block is required to properly calibrate your gage. The 241-BWV2 uses a 3030 master block and the 241 uses a 720 master block. The steps below will guide you through the calibration procedure with pictures of the 595 LCD screen and drawings of the gage to help.

NOTE: Under the ADVANCED SETUP>PORT CONFIG menu the CALSPAN of Port 2a & 2b should be set to 10.00mm

- Press <MENU> to enter the main menu
- “Calibrate” should already be highlighted like the figure below, press <SELECT> or ►

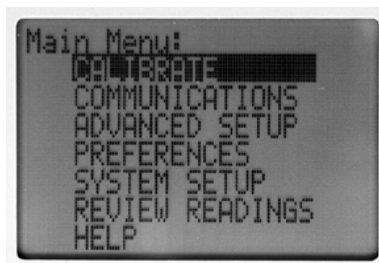

- Highlight Port 2a and press <SELECT>

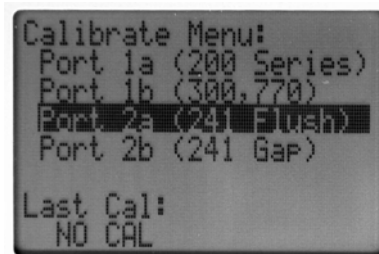

- CAL LOW will be displayed on the screen. Fully extend the flush tip and press <SELECT>

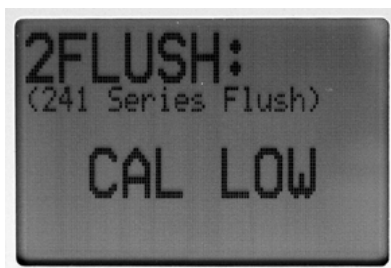

LMI 241

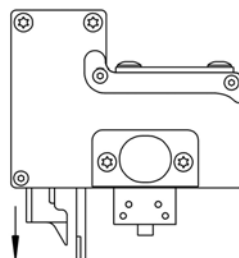

LMI 241-BWV2

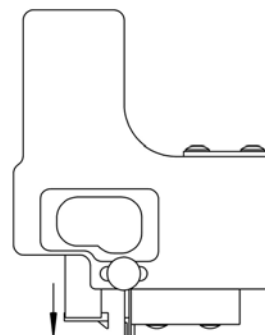

LMI Corporation

- The screen will toggle to CAL HIGH. Fully retract the flush tip and press <SELECT>

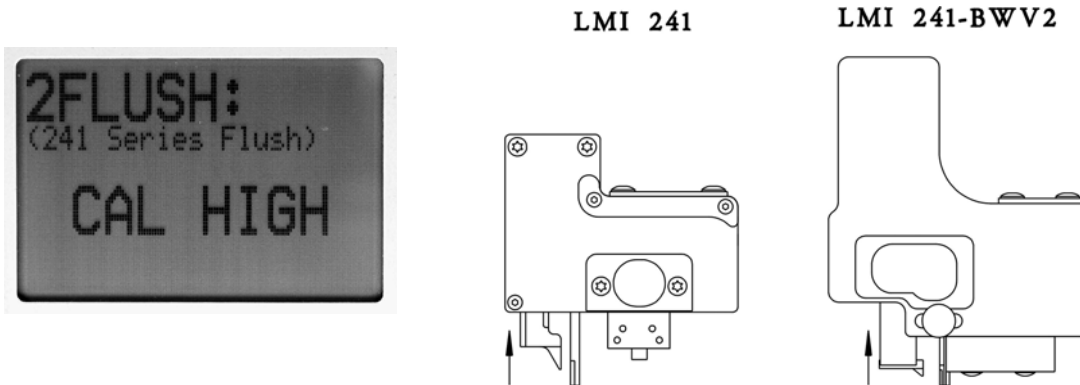

- The screen will then toggle to CAL MASTER. Place the gage in the Master Block and press <SELECT>

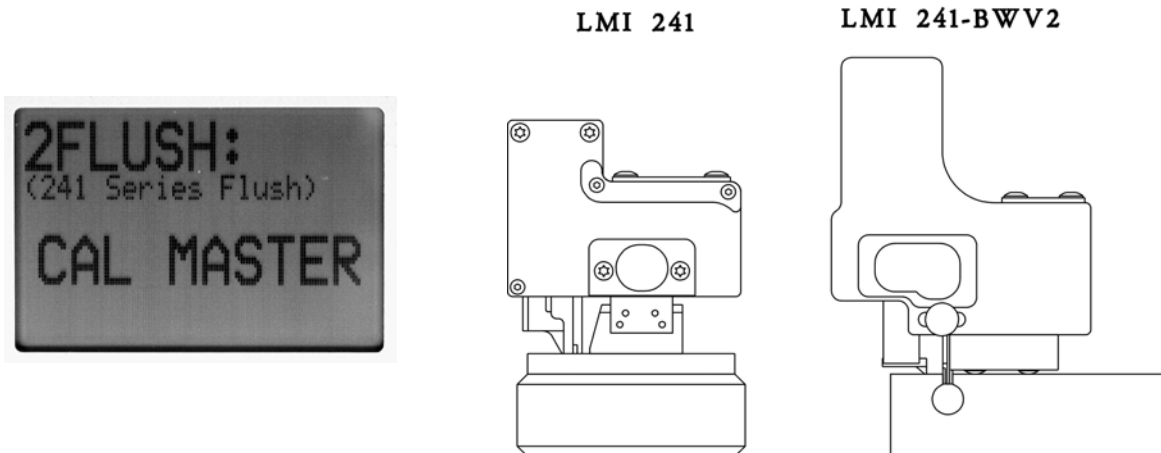

- Flush calibration for port 2 is now complete and you are taken back to the "Calibrate Menu" screen. Highlight Port 2b, press <SELECT>

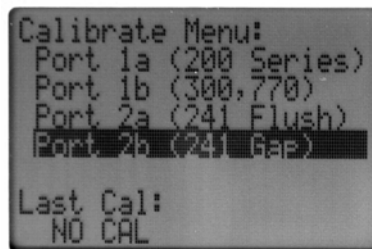

LMI Corporation

- CAL LOW will be displayed on the screen. Fully extend the gap peg for an LMI 241 (fully retract the gap finger for an LMI 241-BWV2/FG) and press <SELECT>

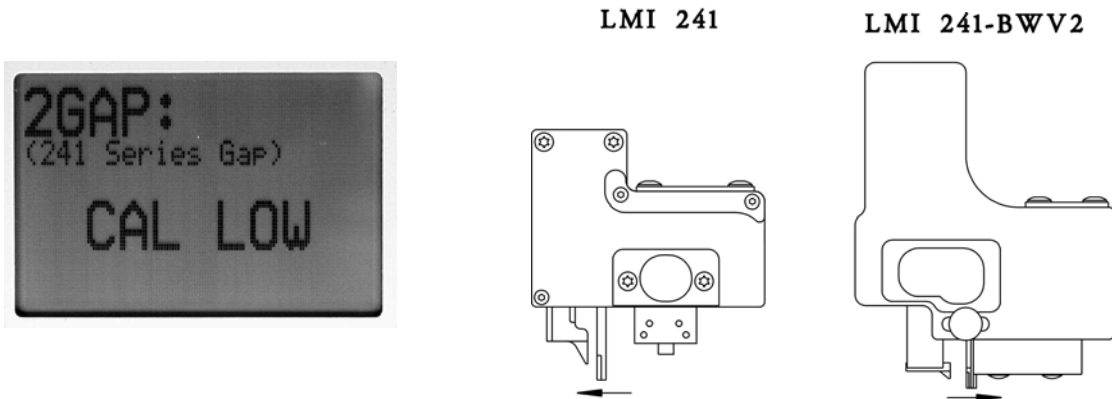

- The screen will toggle to CAL HIGH. Fully retract the gap peg for an LMI 241 (fully extend the gap finger for an LMI 241-BWV2/FG) and press <SELECT>

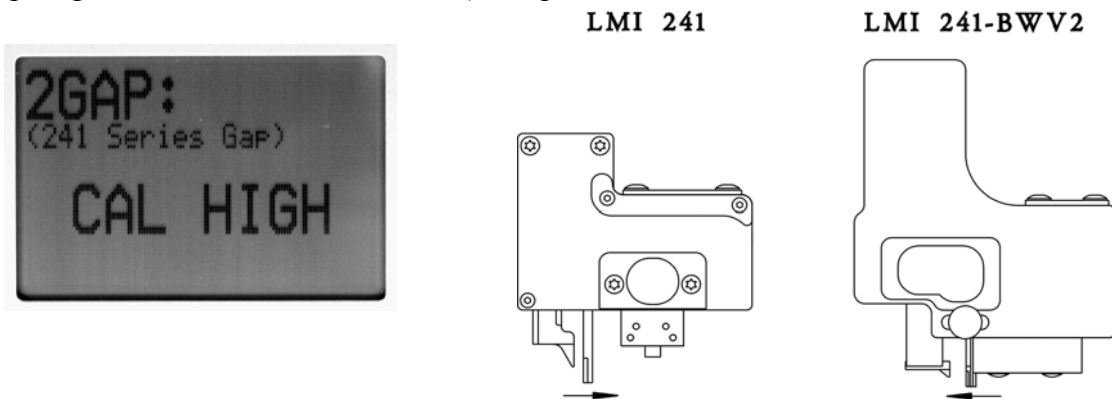

- The screen will toggle to CAL MASTER. Place the gage in the Master Block and press <SELECT>

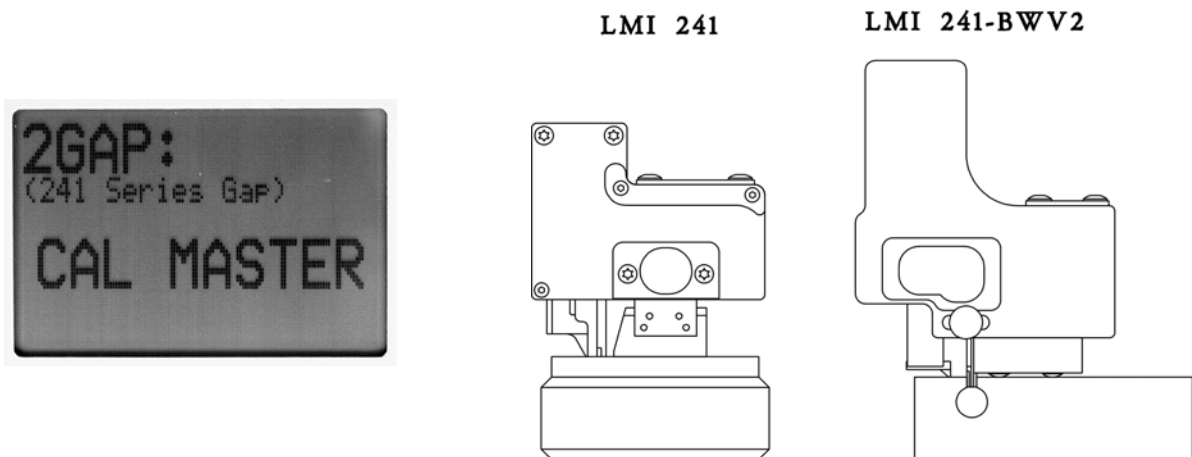

LMI Corporation

- Gap calibration for port 2 is now complete and you are taken back to the “Calibrate Menu” screen. Press <SEND> to exit and view your readings.
- You should be able to view your readings on the screen labeled 2FLUSH over 2GAP. Use the ► or ◀ to toggle between the three gage screens if the two readings are not shown simultaneously (if the “AUTOSEL” is on, you will only view two screens). The screen below shows 2FLUSH with a gage reading of 0.00mm and the 2GAP reading of 3.00mm. Insert the gage back into the Master Block to verify the master points.

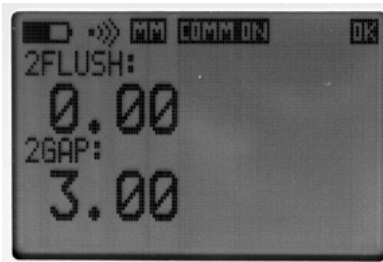

- To reverse the signs, go to the main menu. Go to Advanced setups and hit <SELECT>. Go to Ports Polarity. Press <SELECT>. Choose the port you are using and press <SELECT>...the port readings will change to “Inverted”

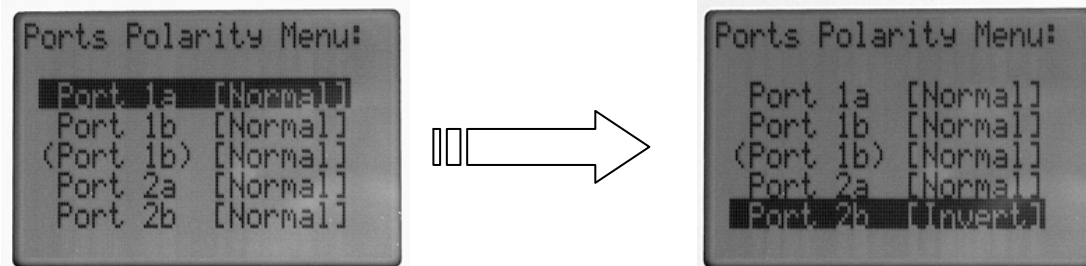

NOTE:

Under the ADVANCED SETUP>PORT CONFIG menu, an OFFSET can be added to the calibration to either Port 2a or 2b. If you want to read actual gap, adjust the offset to 3.00mm. If you are just concerned with deviation then leave the offset value at 0.00mm.

LMI Corporation

4.4 Port 2 Calibrating an Analog TruPosition Probe

For a Digital TruPosition Probe please consult individual product manual for additional instructions.

LMI Corporation

4.5 Port 3 Calibrating a Caliper/ Digital TruPosition Probe

No calibration is required for a Caliper measuring. For a Digital TruPosition Probe please consult individual product manual for additional instructions.

LMI Corporation

4.5 Calibration Errors

The 595 has internal error checking for the calibration steps to help eliminate a bad calibration sequence. If the calibration procedure is exited at any time prior to all three, LOW/HIGH/MASTER steps being completed the calibration will not be stored. If the gage fails to extend and retract to its travel limits for the LOW and HIGH steps an error will display “CAL INVALID” as displayed below. The gage has to be physically moved to avoid this error but it is not fool proof. For instance, the calibration will still be accepted if the gage only strokes 9.0mm instead of a 10.0mm. This error checking is meant to catch the erroneous calibration such as the gage not being plugged in.

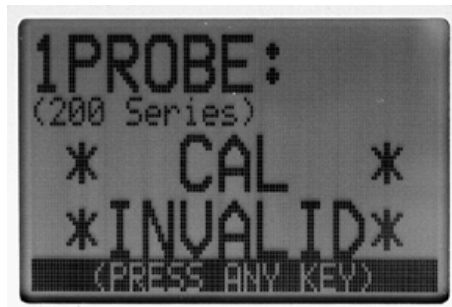

4.6 Reviewing Previous Calibrations

The 595 date and time stamps each calibration. To view the last calibration for any port, press <MENU> and highlight the CALIBRATE menu, press <SELECT>. The last calibration date is shown at the bottom of the LCD screen for each port when highlighted. See sample below.

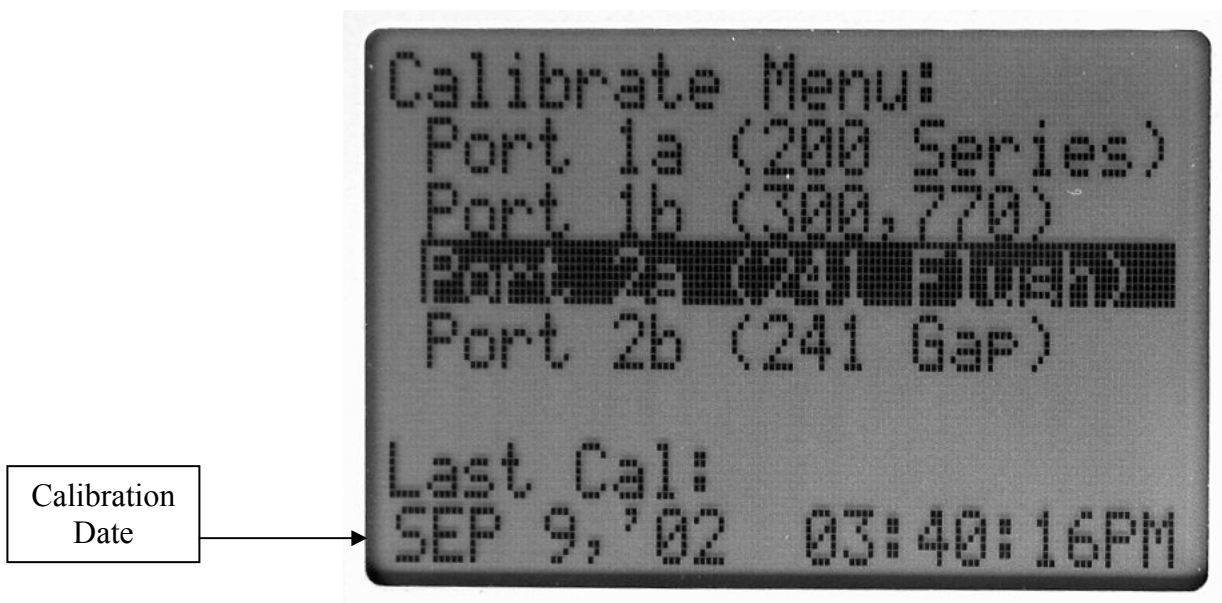

LMI Corporation

SECTION 5: COMMUNICATIONS

5.1 Format (Export Formats)

The LMI 595 can transmit gage readings, date/time stamps and gage labels in the form of “ASCII Characters” to a remote device via the LMI 6020 cable and the RS-232 PORT shown back in Section 2.3. In order to send readings either <SEND> button must be pressed and the communications parameters properly set. To enter the COMMUNICATIONS menu simply press <MENU> and scroll down to highlight COMMUNICATIONS and press <SELECT>

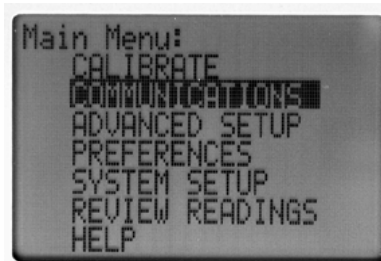

The sub-menu for CALIBRATIONS is shown below:

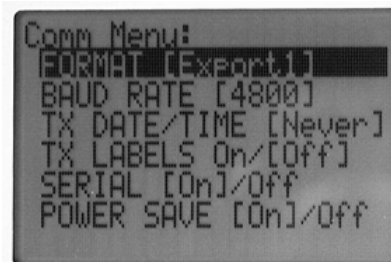

- Press <SELECT> to enter the FORMAT menu as shown below.



The following describes the serial communication protocols supported by the 595.

EXPORT 1

The Export 1 format is a “generic” data transmission format. Positive data values are transmitted without any sign character; negative values are preceded with a minus sign (-). All data values are followed by a carriage return (CR) and linefeed (LF). If the unit is configured to transmit labels, a space followed by the label immediately precedes the CR/LF. If the unit is configured to transmit the Date/Time, they will be transmitted before the first (or only) data value, using this format:

MM/DD/YY HH:MM:SS

Followed by a CR/LF.

LMI Corporation

EXPORT 2

The Export 2 format sends a plus sign ('+') before all positive data values, and a minus sign ('-') before all negative data values. All data values are followed either "mm" or "in", depending on the active units of measure, followed by a TAB character. If the unit is configured to transmit labels, a space followed by the label immediately precedes the TAB. If the unit is configured to transmit the Date/Time, they will be transmitted before the first (or only) data value, using this format:

MM/DD/YY HH:MM:SS

Followed by a TAB.

EXPORT 3

The Export 3 format is the "Tab Delimited" format. Positive data values are transmitted without any sign character; negative values are preceded with a minus sign ('-'). If two data values are transmitted, a TAB character follows the first. A CR/LF follows the last (or only) data value. If the unit is configured to transmit labels, a TAB followed by the respective label immediately follows each data value, before the succeeding TAB or CR/LF. If the unit is configured to transmit the Date/Time, they will be transmitted before the first (or only) data value, using this format:

MM/DD/YY<TAB>HH:MM:SS<TAB>

(Note: <TAB> represents the TAB character in the Date/Time string.)

EXPORT 4

The Export 4 format is the "Comma Delimited" format. Positive data values are transmitted without any sign character; negative values are preceded with a minus sign ('-'). If two data values are transmitted, a COMMA character (,) follows the first. A CR/LF follows the last (or only) data value. If the unit is configured to transmit labels, a COMMA followed by the respective label immediately follows each data value, before the succeeding TAB or CR/LF. If the unit is configured to transmit the Date/Time, they will be transmitted before the first (or only) data value, using this format:

MM/DD/YY,HH:MM:SS,

MITUTOYO

The Mitutoyo format is actually a serialized rendition of Mitutoyo's standard 4-bit-wide SPC protocol. All data values are transmitted as a string of 13 characters, according to this format:

- d1) 'F'
- d2) 'F'
- d3) 'F'
- d4) 'F'
- d5) '0' if positive; '8' if negative
- d6-11) Digits (6)
- d12) Decimal point location (xxxx.xx = 2, etc.)
- d13) '0' if mm; '1' if inches

All 13-character data values are followed by CR/LF. If the unit is configured to transmit labels, a space followed by the label immediately precedes the CR/LF. If the unit is configured to transmit the Date/Time, they will be transmitted before the first (or only) data value, using this format:

MM/DD/YY HH:MM:SS

Followed by a CR/LF.

LMI Corporation

5.2 Baud Rate

The Baud Rate must be matched to whatever device you are trying to send readings to. To access the BAUD RATE menu press <MENU>, highlight COMMUNICATIONS and press <SELECT>.

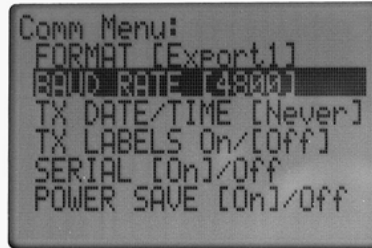

- Scroll down to highlight BAUD RATE and press <SELECT> to enter the BAUD RATE menu as shown below. Highlight the desired baud rate and press <SELECT>. Notice the standard ASCII character format is listed at the bottom of the screen which is 8 data bits and no parity.



5.3 TX Date/Time (Sending Date/Time Stamp)

The TX Date/Time option can be used to send the date and time when you transmit readings to a PC. The frequency of sending this information is configurable. To access the TX Date/Time menu press <MENU>, highlight COMMUNICATIONS and press <SELECT>.

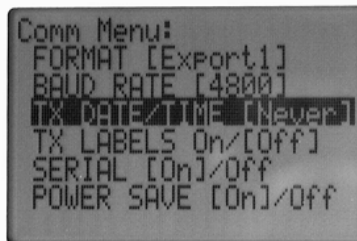

- The default is set to “NEVER” send the date and time. To configure, highlight TX Date/Time and press <SELECT> to enter the menu as shown below. Highlight the desired frequency and press <SELECT>.

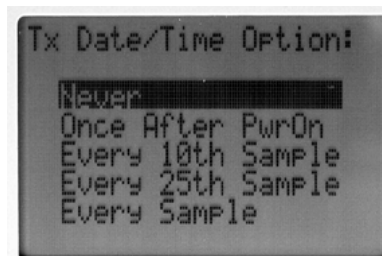

LMI Corporation

5.4 TX Labels (Sending Labels)

The TX Labels option can be used to send the gage label with the gage reading. This is extremely useful in order to match the readings with the gage port. Such as sending two readings on port 2 the FLUSH and GAP labels will attach to their respective reading. This options are either On or Off. The labels are configurable and will be covered in section 6. The default option for sending labels is set to OFF.

- To turn labels ON, press <MENU>, highlight COMMUNICATIONS and press <SELECT>. Highlight TX Labels On/[Off] and press <SELECT> again. The item selected will be enclosed in brackets. The picture below shows the option turned ON.

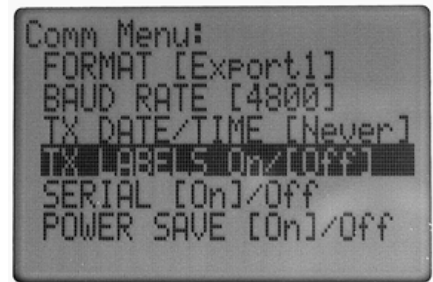

5.5 Serial [On]/Off

To send readings to the RS-232 PORT the SERIAL option must be turned ON. By default this option is turned ON. The ON/OFF status is shown at the top of the LCD on the gage reading screen in the form of COMM ON or COMM OFF (Reference section 2.6).

- To turn Serial OFF, press <MENU>, highlight COMMUNICATIONS and press <SELECT>. Highlight "Serial [On]/Off" and press <SELECT> again. The item selected will be enclosed in brackets. The picture below shows the option turned ON.

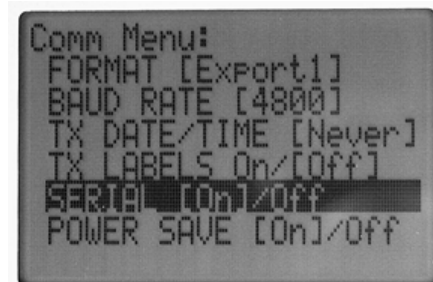

5.6 Power Saver [On]/Off (For RF option "ONLY")

The following settings need to be set on the 595 in order for the RF antennas to properly work. This is the sole purpose of this option.

- Press <MENU> to enter the main menu and select the <COMMUNICATIONS> sub-menu.
- Select the Export Format, which is EXPORT #3 if you are sending data to LMI's DATA COLLECT software.
- Set the Baud Rate to 9600 on the 595 and also on the PC.
- Set TX DATE/TIME to <NEVER>
- Turn LABELS <OFF>
- Make sure SERIAL is turned <ON>
- **Most important, make sure the Serial POWER SAVE option is turned <OFF>.**



LMI Corporation

SECTION 6: ADVANCED SETUP MENU

6.1 Advanced Setup

The LMI 595 has added a lot of features to customize each gage port. Options to add offsets, port labels, adjust how many decimal places are viewed and even a new feature called Null Meter that is used for centering glass. All these options will be covered in this section on Advanced Setup. To enter the ADVANCED SETUP menu simply press <MENU> and scroll down to highlight ADVANCED SETUP press <SELECT>

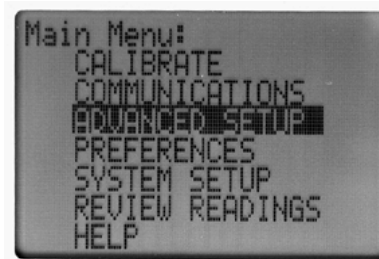

All of the following sections will start once you have entered the ADVANCED SETUP menu. The menu is shown below. Two of the menu items, CONFIG PORTS and PORTS DISPLAY, each have further sub-menus that continue with other options.

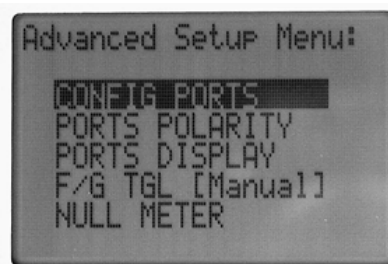

LMI Corporation

6.2 Configure Ports –LMI 200 Probes & LMI 241 Gages

- To configure individual ports, highlight CONFIG PORTS and press <SELECT>

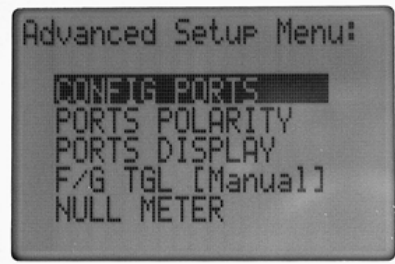

- The screen will list the four possible port selections for the gages. Highlight the desired port and press <SELECT>

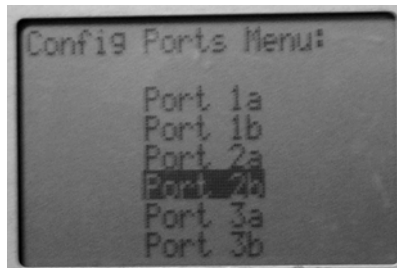

- Each port has a sub-menu of possible options, as shown below. Each item will be displayed on the screen. To access each option simply, highlight it and press <SELECT>

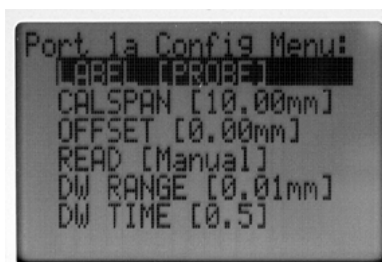

LMI Corporation

6.2.2 Configure Ports TruPosition Probe

- To configure individual ports, highlight CONFIG PORTS and press <SELECT>

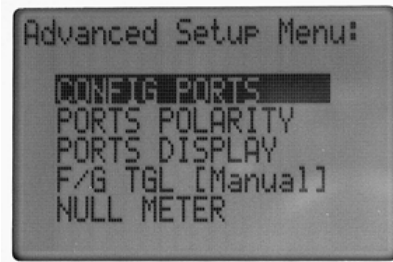

- The screen will list the 2 possible Port selections (Port 3A and Port 3B). Highlight the desired port (3A) and press <SELECT>.

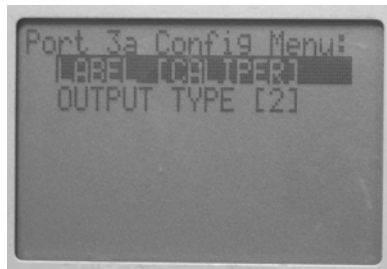

- Port 3A/B has 3 Display Options:

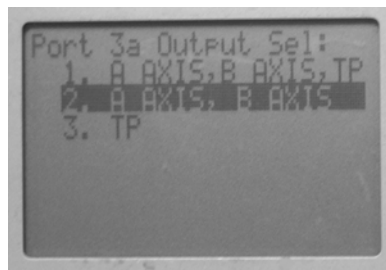

1. A Axis, B Axis, TP –will display all readings (A Axis, B Axis and TP Calculation) of the TruPosition on an Export.
 2. A Axis, B Axis – will display both the A Axis and B Axis of the TruPosition on an Export
 3. TP – will only display the TruPosition Calculation on an Export.
- To select the desired handheld display format highlight the selection and press <SELECT>

Note: Factory Default Display Option is set to A Axis and B Axis ONLY.

LMI Corporation

6.2.2 Labels

Labels are the items displayed next to the Port # on the gage reading screen and are also the text labels that can be attached to readings when sent to a PC.

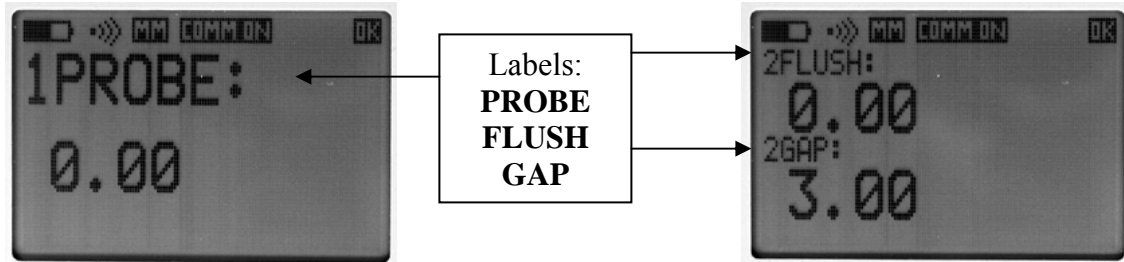

- To change the current label (displayed in brackets in the “Config Menu”) simply highlight LABEL and press <SELECT>. A list of possible labels is displayed. Use the arrow keys to highlight and press <SELECT>



Port 1 Label selection window

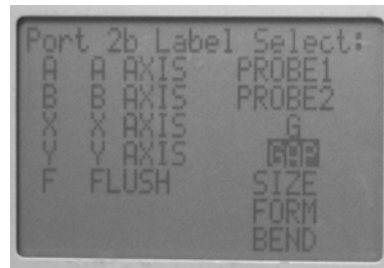

Port 2 Label selection window



Port 3 Label selection window

LMI Corporation

6.2.3 CALSPAN

CALSPAN or calibration span is the full travel of the gage from fully extended to fully retracted position. It is imperative for accuracy and the three step calibration to match the CALSPAN with gage travel. Most LMI gages are set to a 10.0 mm span and that is what the default value is. Some LMI gages like the 200-SF and 2079 gap gage have a 22.0 mm stroke and the CALSPAN needs to be changed accordingly. To adjust the value simply highlight CALSPAN and press <SELECT>. Use the arrow keys to adjust the value and press <SELECT> when complete.

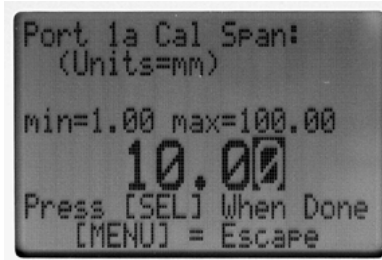

6.2.4 Offsets

Offsets are used to add a known value to the zero or master point. This is commonly used for the gap measurements on a 241 flush and gap gage. Instead of reading a 0.0 mm gap at nominal the value should read 3.0 mm because the master block is set to a 3.0 mm gap. For an offset you would simply enter 3.00 instead of leaving the offset at the 0.00 default value. To adjust the value simply highlight OFFSET and press <SELECT>. Use the arrow keys to adjust the value and press <SELECT> when complete.

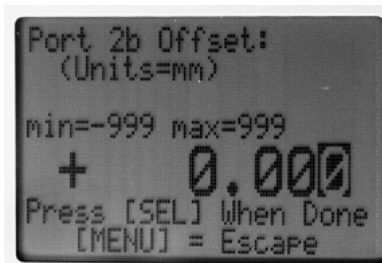

LMI Corporation

6.2.5 Auto Read, Dwell Range and Time

The READ, DW RANGE, and DW TIME menu items are all related to each other and determine whether or not a reading is stable and can be sent to a PC. The READ menu item is either set to OFF, MANUAL, or AUTO with MANUAL being the default.

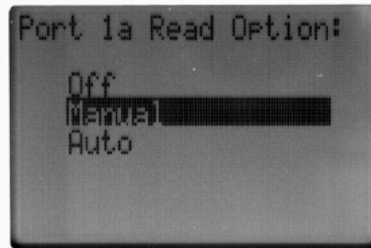

With the “Read Option” set in MANUAL mode, the “OK” icon in the top right corner of the LCD will appear to indicate a stable reading. The <SEND> key can then be pressed to sample the reading but ONLY if the “OK” icon is visible. The Dwell Range and Dwell Time determine whether or not a reading is stable. With the default values of Dwell Range set at .01mm and the Dwell Time at 0.5 seconds, the gage reading has to remain stable for a 1/2 second and not bobble more than 0.01 mm.

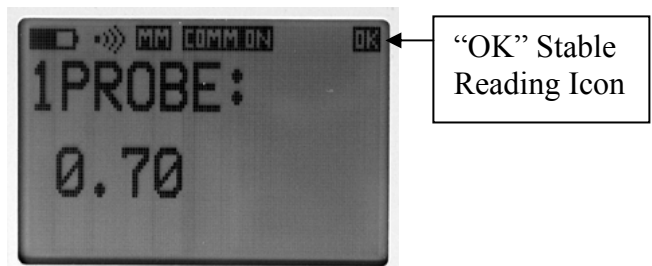

With the “Read Option” set to AUTO, it is used for fixture checks using a 200 probe where you insert the gage into a bushing until it hits the shoulder and the reading will automatically SEND when the reading is stable without pressing the <SEND> key. In AUTO mode, after a sent reading is taken, the gage must move past a threshold to send another reading. This eliminates the chance of sending more than one reading at a given point. With the “Read Option” OFF, the <SEND> key will send the readings regardless of the “OK” stable reading icon.

To adjust these three options simply highlight the menu option and press <SELECT>. Use the arrow keys to change the value and press <SELECT> when complete.

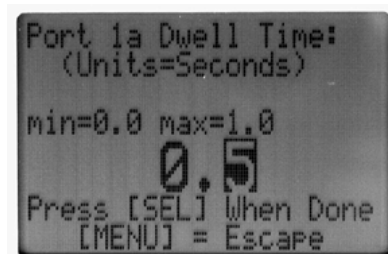
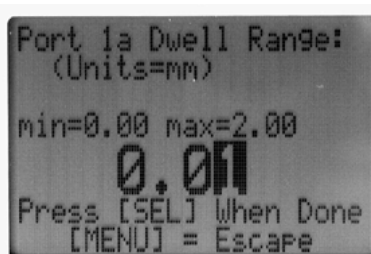
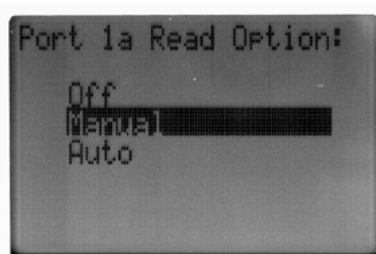

LMI Corporation

6.2.6 Auto Select for a 300/770

AUTOSEL or Auto Select is only found in the menu for port 1b. The 200 Probe and the 300/770 flush and gap gage share port 1 on the 595. The AUTOSEL option is a way to automatically toggle to the proper gage reading screen. All 300/770 gages manufactured as of 1996 are compatible with this feature. The two options for AUTOSEL are MANUAL or AUTO. MANUAL is the default mode. In Manual mode, the operator must toggle to either 1PROBE or 1FLUSH depending on which gage is plugged in. In AUTO mode, the screen will automatically display "1FLUSH" when a 300/770 is plugged into port 1 and "1PROBE" when a 200 probe is plugged in. To change AUTOSEL to AUTO mode simply highlight AUTOSEL and press <SELECT>.



LMI Corporation

6.3 Ports Polarity

This option is used any time you need to reverse the polarity on your gage readings. The following instructions and pictures will explain how to set it up.

1. From the “Main Menu:” arrow up ▲ or ▼ down to <Advanced Setup> and hit “Select”.
2. Arrow up ▲ or ▼ down to “Ports Polarity” and hit “Select”.
3. You will now have 5 port selections.
 - Port 1a is for 200 series Probes.
 - Port 1b is for 300/770 “FLUSH”
 - (Port 1b) is for 300/770 “GAP”
 - Port 2a is for 241 BW and BWV2 “FLUSH”
 - Port 2b is for 241 BW and BWV2 “GAP”
4. It is common for Port 2b (Gap) to be “Inverted” for use with the 241 series transducer.

1) From the “Advanced Setup Menu” screen, highlight “Ports Polarity” and hit <Select>

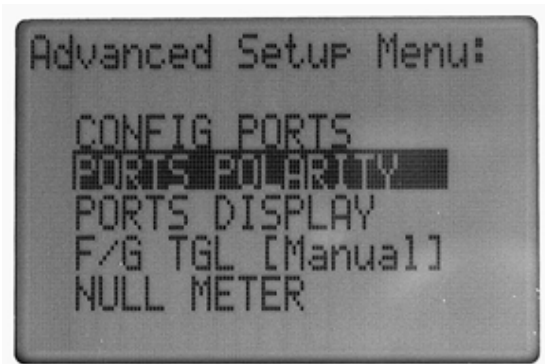

2) From the “Ports Polarity Menu” screen, highlight the port you need and hit <Select>

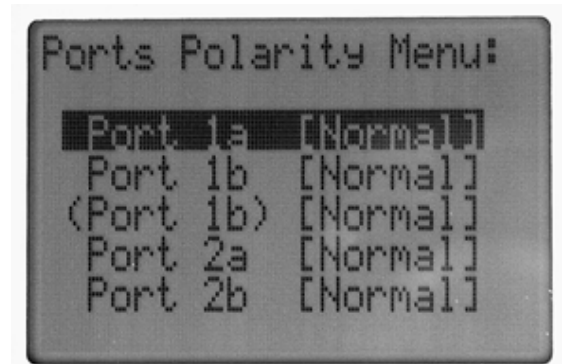

3) After selecting, hit <Select>. The port will change to [Invert]

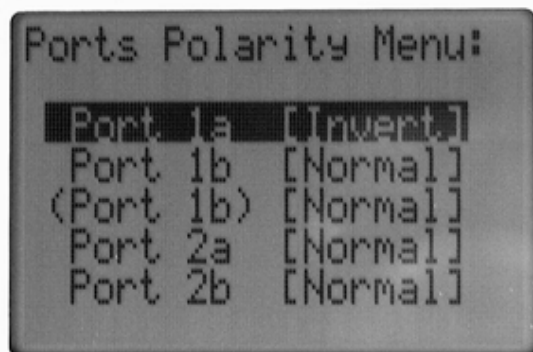

4) Port 1b has two entries, Port 1b for “Flush” & (Port 1b) for “Gap”

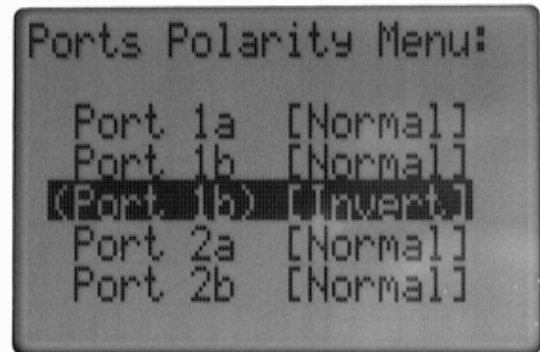

LMI Corporation

6.4 Ports Display

The Ports Display menu is used to set the number of decimal places seen on the LCD screen, the number of decimal sent to the PC and to configure any rounding parameters. To configure individual ports, highlight PORT DISPLAY and press <SELECT>

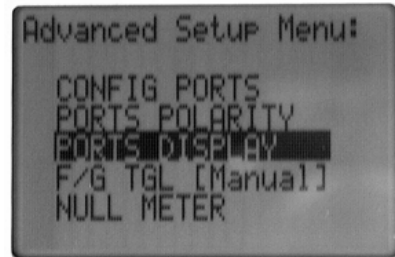

- The three display options are listed in the sub-menu below with each port (Port #1 and #2) having its own set of options. To access each option simply highlight and press <SELECT>

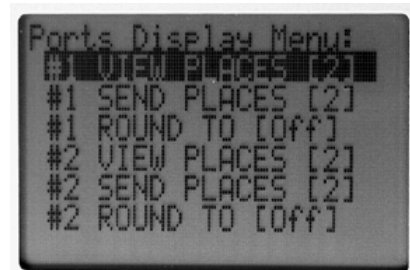

6.4.1 View Places

View Places is the number of decimal places that the gage reading displays on the LCD screen. Port #1 and #2 have their individual settings and the number in brackets is the current setting. To change, highlight the item and press <SELECT>. Scroll to the desired value and press <SELECT>

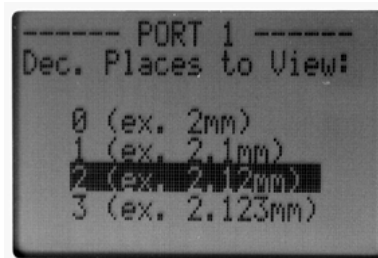

LMI Corporation

6.4.2 Send Places

Send Places is the number of decimal places that is sent to the PC when the <SEND> key is pressed. The gage reading displayed on the LCD screen could be viewed at 2 decimal places while the actual readings sent to the PC are three decimal places. Port #1 and #2 have their own individual settings. To change, highlight the item and press <SELECT>. Scroll to the desired value and press <SELECT>

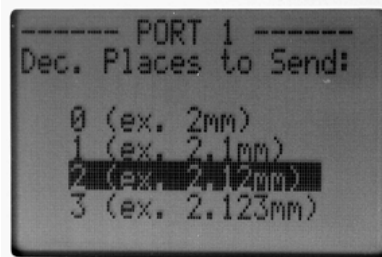

6.4.3 Round To

Round To is an option used to round the gage reading to a certain whole value, such as rounding 1.02 mm to 1.00 mm. The default value for ROUND TO is “No Rounding”. Port #1 and #2 have their individual settings. To change, highlight the item and press <SELECT>. Scroll to the desired value and press <SELECT>



6.5 F/G Toggle

F/G Toggle or Flush/Gap Toggle is an option for port 1b when using a 300 or 770 flush and gap gage. The only two options are MANUAL or AUTO with MANUAL being the default as shown below in brackets. When set to MANUAL the 1FLUSH and 1GAP readings have to be manual switched by pressing the <SELECT> key. With AUTO turned on, every time the <SEND> key is pressed to send a reading the display will toggle back and forth between the 1FLUSH and 1GAP readings. To turn AUTO on, highlight F/G TGL and press <SELECT>

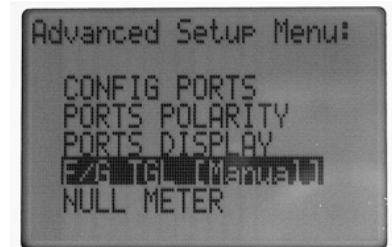

LMI Corporation

6.6 Null Meter

Null Meter is an option for centering glass. In order to use Null Meter the LMI 595 -560 model should have been purchased, which included a “Y” cable and an AC wall adapter. The “Y” cable should be plugged into Port 2 of the 595 and two 200 Probes should be plugged into the two ports on the “Y” cable using a LMI 6009 cable. Prior to selecting the Null Meter option the two 200 Probes need to be calibrated.

Follow the 200 Series Probe calibration procedure described in section 4.1 for each 200 but instead of using Port 1a you will be using Port 2, where the “Y” cable is plugged into. One 200 Probe will use Port 2a labeled 2Flush and one 200 Probe will use Port 2b labeled 2Gap. To make identification easier, you can change the port labels to PROBE1 and PROBE2 to coincide with the numbers on the “Y” cable. After calibration, highlight Null Meter and press <SELECT>

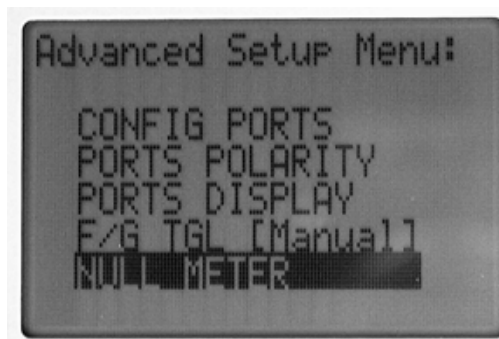

The following screen is the Null Meter with reading and a meter below with a scale of +/- 2.0 mm. The reading and the meter tells the operator how much to move the glass either right or left. The meter will only display +/- 2.0 mm but the reading will still display the full scale of the gages. Figure 1 has a reading of 0.0 and therefore does not require the glass to shift. Figures 2 and 3 have an added arrow to tell the operator which way to shift the glass. If you were looking Figure 2, you would need to shift the glass 0.5mm to the right to be centered. In figure 3, you would need to shift the glass 0.4 mm to the left to be centered. To exit the Null Meter screen, press <MENU>.

NOTE: If you power off the 595 while viewing the Null Meter the next time the 595 is powered on it will return to the Null Meter.

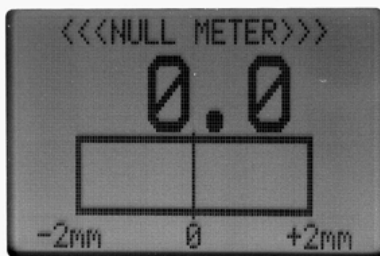

Figure 1

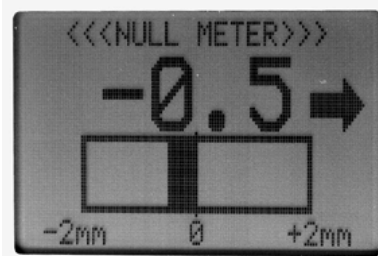

Figure 2

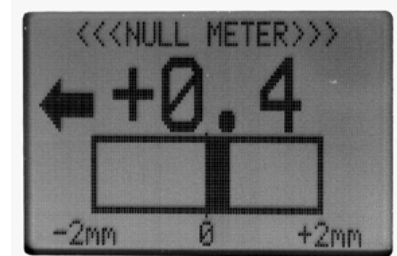

Figure 3

LMI Corporation

Calibrating the Null Meter

Equipment required:

- (1) 595 -560
- (1) "Y" connector
- (2) LMI 200 probes
- (1) LMI 210 Master Block
- (2) LMI 6009 Cables

Calibration is done using the same procedure as the LMI 200 probe (pages 12 & 13), except that you will be calibrating Probe #1 on "Port 2a" and Probe #2 on "Port 2b".

NOTE:

It is recommended that you change the labels on these two ports to read "PROBE1" and "PROBE2" instead of "FLUSH" & "GAP".

LMI Corporation

SECTION 7: PREFERENCES MENU

7.1 Units

The LMI 595 can be customized by the user using the PREFERENCES menu. To enter the PREFERENCES menu press <MENU> and scroll down to highlight PREFERENCES and press <SELECT>

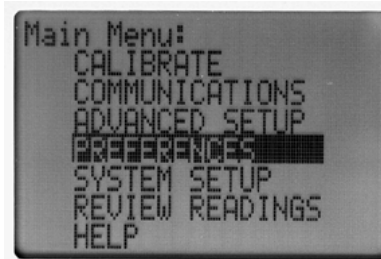

The sub-menu for PREFERENCES is shown below. The Units menu toggles the 595 to display the values in either Metric (mm) or English (inches). This parameter is a global setting and will format the gage readings as well as the menu selections. The Metric selection is shown below on the left with the English setting shown on the right. To switch Units, highlight and press <SELECT>

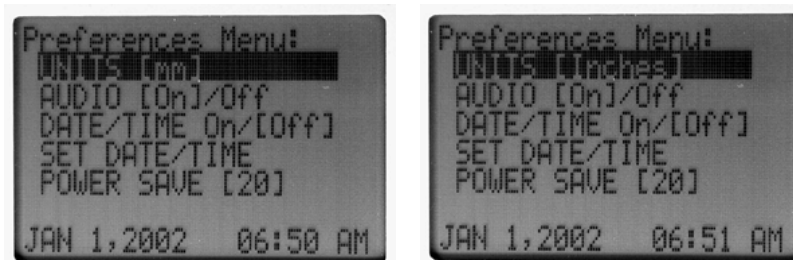

7.2 Audio

The Audio tone by default is “ON” and can be turned “OFF” by highlighting AUDIO and pressing the <SELECT> key. The Audio tone will not sound when selecting menu items or to signal that a reading has been sent, but it will still be active when calibrating.



LMI Corporation

7.3 Date/Time Display on Screen

The 595 has a real time clock on board and needs to be set the first time you power the unit on. The Date/Time option allows you to display the current date and time at the bottom of the gage reading screen. The gage reading screen shown below has the Date/Time option turned ON. By default the option is turned off as shown below in brackets. To turn ON, highlight DATE/TIME and press <SELECT>

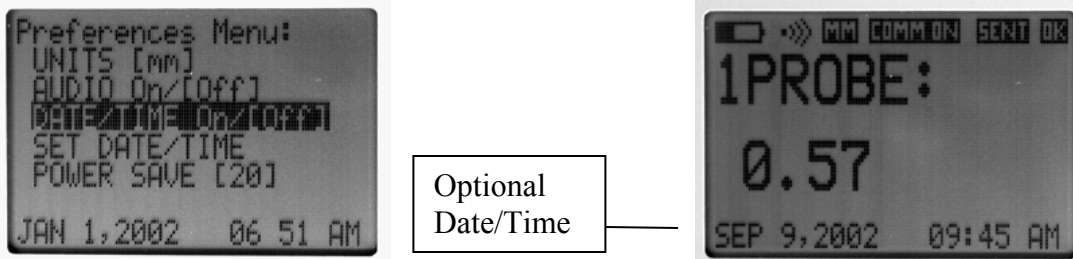

7.4 Set Date/Time

To change the date or time any time after the initial power on, highlight the SET DATE/TIME option and press <SELECT>. Use the arrow keys to change the date and time and press <SELECT> when finished.



LMI Corporation

7.5 Power Save

The Power Save option will set a delay (in minutes) to automatically power the unit OFF if no keys have been pressed. The default time delay is 20 minutes. If you want to disable the option because you are plugged in to the AC wall adapter set the Power Save option to zero. To adjust the Power Save feature, highlight POWER SAVE and press <SELECT>. Use the arrow keys to change the value and press <SELECT> when finished.

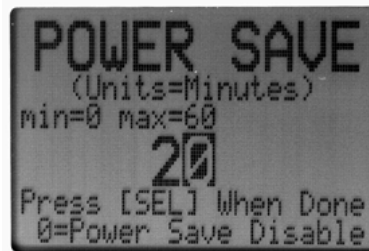
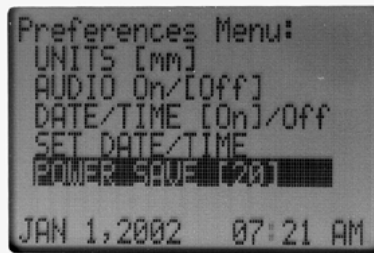

LMI Corporation

SECTION 8: SYSTEM SETUP

8.1 Security

The user can lock all of the features that have been set by turning the Security feature ON. The only thing allowed once the Security is ON is that the operator can view and send readings. All of the menus and options are inaccessible, including calibration. By default the Security option is turned OFF. To enter the SECURITY menu press <MENU> and scroll down to highlight SYSTEM SETUP and press <SELECT>

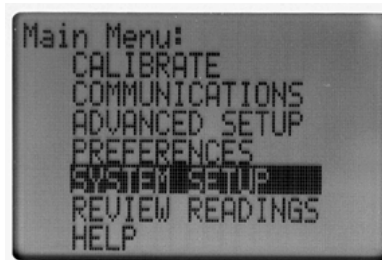

- The sub-menu for SYSTEM SETUP is shown below. To turn Security On,, highlight SECURITY and press <SELECT>

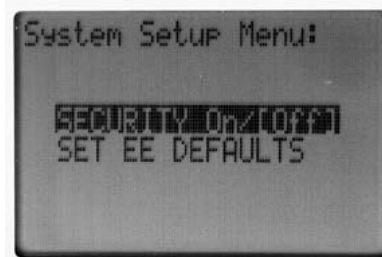

- The display will verify again that you want to turn the Security feature ON and enable a password. The default is "N" (no), but use the ▼ to change the confirmation to a "Y" (yes). You will be asked to enter a 4-digit numerical password. Use the arrow keys to change the password and press <SELECT> when finished. REMEMBER THE PASSWORD, because it is required to unlock all menus and calibration. There is a way to disable the security feature if the password is forgotten. The default password which will unlock every 595 is "5950".



LMI Corporation

8.2 Set EE Defaults

The SET EE Defaults option is a way to return your 595 to the original settings for the manufacturer. Use this feature only when necessary since it will erase all setting, preferences and calibrations that have been established. Once you have selected the option you will be asked to confirm your choice again. Press the <SELECT> to continue or press any other key to abort.

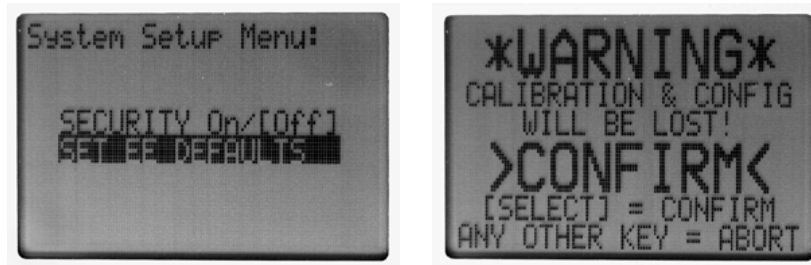

LMI Corporation

SECTION 9: REVIEW READINGS

9.1 Review Latest Readings

Every reading that is sent to the PC is stored in a temporary memory slot called SRAM. The SRAM will hold the last 100 samples taken. Once the 100 readings have been exceeded the data is overwritten with the latest data. The data will remain in the SRAM until the unit is powered off. At any time prior to powering off, you can review the values by going into the REVIEW READINGS menu. To enter the REVIEW READINGS menu press <MENU> and scroll down to highlight REVIEW READINGS and press <SELECT>

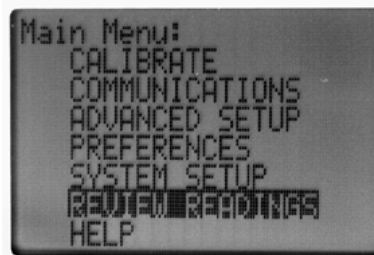

- The sub-menu for REVIEW READINGS is shown below. To view the latest readings, highlight RVW LATEST READINGS and press <SELECT>

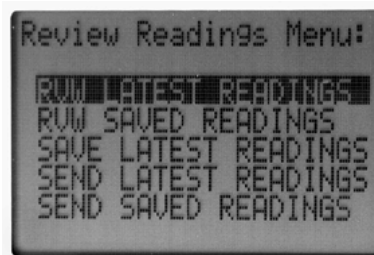

- The readings are date/time stamped as to when the data was taken. They are also listed from the most previous reading to the oldest reading. The gage port and label also is shown with the reading. The numbers indicate which reading you are currently viewing and the total number of stored readings. Use the ▲ arrow to scroll through the readings. Any reading sampled on port 2 will display both values as one entry.



LMI Corporation

9.2 Saving Readings and Reviewing Saved Readings

There is a way to permanently save the group of 100 Latest readings we just reviewed so they will not be lost when powered off. The menu option SAVE LATEST READINGS will store every reading shown in the RVW LATEST READING menu to the EEPROM. You can then RVW SAVED READINGS even after you power down. The EEPROM has a limited write life of 100,000 times so the 595 is not designed to be a data collector for daily downloads. Also, if there is data in the saved list and you <SELECT> save latest reading the values already saved will be overwritten. The screens below show the message after a successful save and the RVW SAVED READINGS.

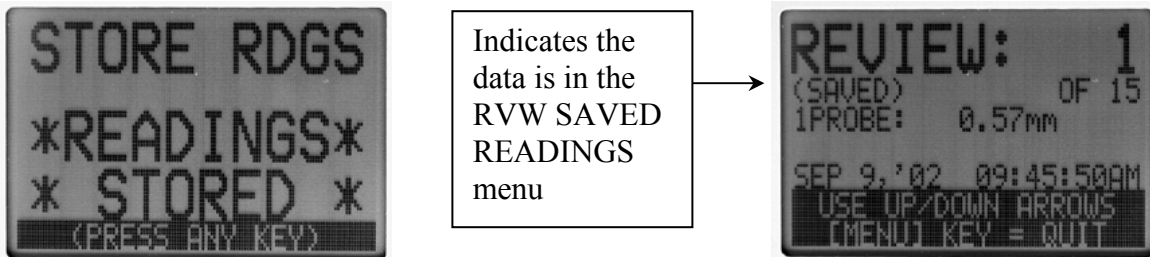

9.3 Sending Saved and Latest Readings

Both memory locations for the list of 100 readings can be sent to a PC as a string of data. Prior to sending the data, make sure your communication parameters have been setup (refer to section 5). To send your data, connect the 595 to your PC using an LMI 6019 cable (option) and highlight, SEND LATEST READINGS or SEND SAVED READINGS and press <SELECT>. When complete the screen will display how many readings were sent and display "ALL VALUES SENT". If you have the label or date/time option selected it will also include this information in the data string.

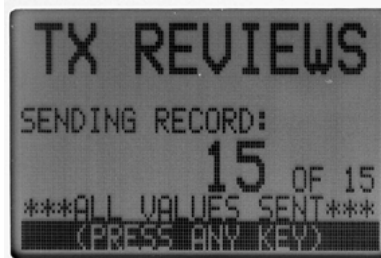

9.4 Setting up your PC to receive data from the 595

Before starting your PC, connect the LMI 6020 cable (option) to a 9 pin COM port on the back of your computer and plug into the RS-232 Port on your 595 now you can start your PC.

From the startup icon on your PC, go to Programs\Accessories\Communications\Hyper Terminal. Double click on the Hypertrm.exe icon. The "New connection" screen will open...give your connection a name and choose an icon. Be sure to connect using the proper COM port that you are connected to (COM 1). Set the COM1 properties as follows: Bits/sec @ 9600, Data bits @ 8, Parity at None, Stop bits at 1, Flow control @ Hardware. Hit OK. (Match the Bits/sec to the Baud rate of the 595)

You now have HyperTerminal connections to your 595.

LMI Corporation

SECTION 10: HELP

10.1 Help

To enter the HELP menu press <MENU> and scroll down to highlight HELP and press <SELECT>

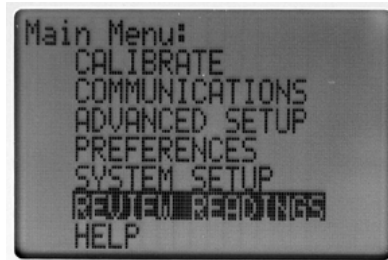

The help menu will display the “Code” version of your 595 and all the necessary information in order to contact LMI.

Current Code Version of 595: **Code Version 1.15**