

This drawing contains designs and other information which are property of LMI Corp. This drawing may not, in whole or in part, be duplicated or disclosed or used for manufacture of the part disclosed herein, without the prior written permission of LMI Corp. LMI is dedicated to continuous product development and therefore reserves the right to modify the design without notice

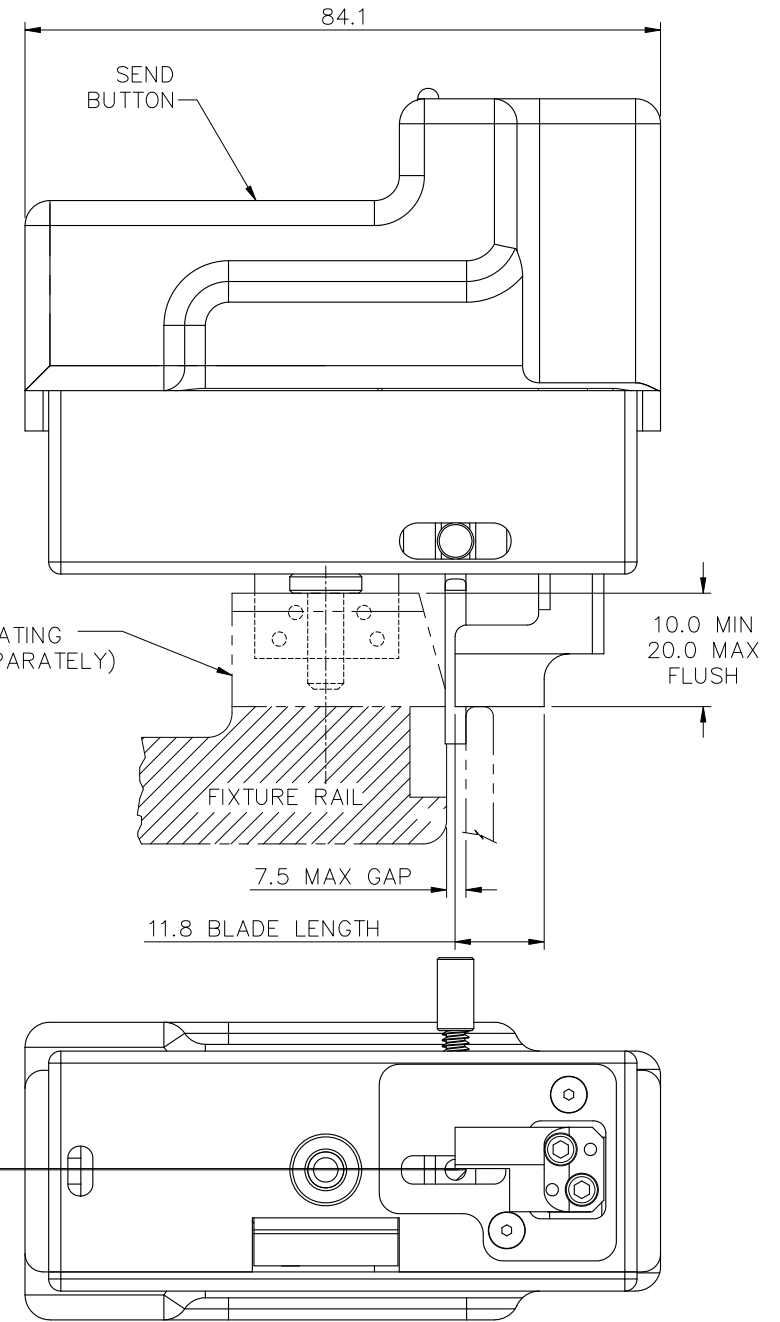
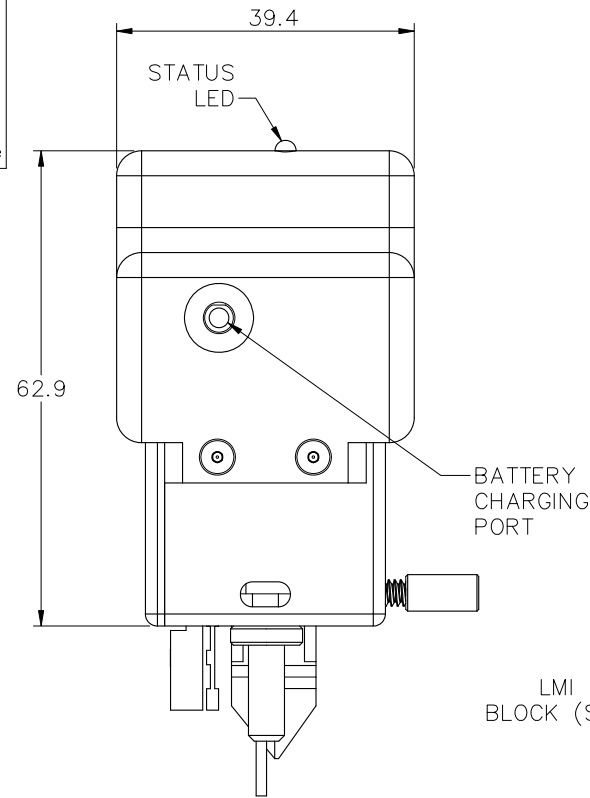

TRACING TEMPLATE

NOTE: 10MM OF TRAVEL FOR BOTH FLUSH AND GAP CHECKS.
FLUSH CHECK TIP MOVES INDEPENDENT OF GAP CHECK PEG

MANUFACTURED UNDER ONE OR MORE OF THE FOLLOWING PATENTS:
#4345380; #4731935; #4787151; #4831742; #4831743; #4843727; #5787017

LMI

PHONE #(810) 714-5811

TITLE: LMI 241W-B, FLUSH & GAP GAGE
MODEL NUMBER: LMI 241W-B (TWO-FOR-ONE)
SHEET: 1 OF 1
REV DATE: 02/05/15